

## ME131

# Multi-circuit Smart Energy meter V1.1

Model No. for master meter ME131

ME131M	85-265VAC/110-370VDC, 45-60Hz
ME131M-24VDC	Power supply 24V DC
ME131HV-480V	Power supply 480V



### ME131 Multi-circuit Smart Energy meter

Master meter: ME131M

Submeter: ME131S

\* Accuracy: 0.5S

\* Sensor: CT or Rogowski coil, with RJ12 port

\* Monitor up to 32 circuits

(Single phase/Three phase)

\* Integrated power supply for master meter and submeter

\* Communication: Modbus-RTU, RS485,

\* Max baud rate: 38.4 kbps

\* Test version software



Compact and space-saving  
Plug design  
Centralized installation  
Easy maintenance  
Excellent function  
Economical cost



ME131 multi-circuit smart energy meter is compatible with both Rogowski coil and voltage-output split core current transformer, which could realize dismantling-free conductor test, simplify test procedures and save construction costs.



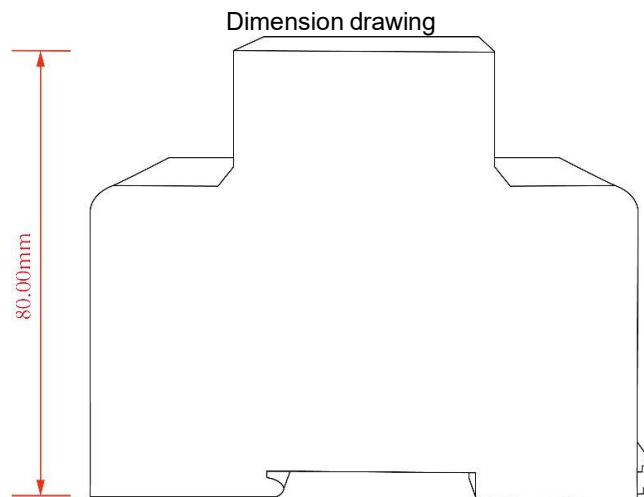
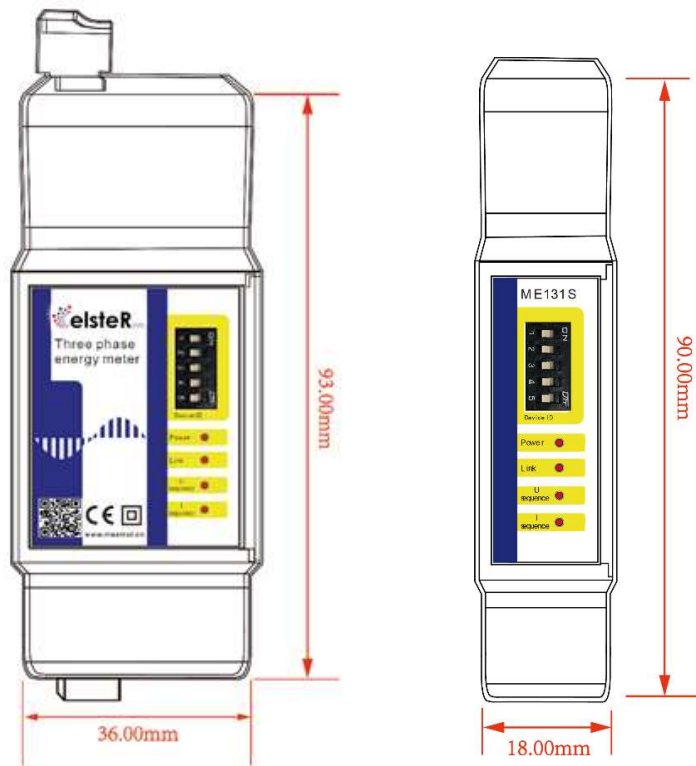
## Contents

1 Product description .....	1
2 Measurement parameters.....	3
3 Accuracy and certification .....	4
4 Connection .....	5
4.1 Power supply .....	6
4.1 Voltage and current input.....	6
4..1 Set current input parameter .....	6
4..2 Test version software.....	7
4..3 Voltage and current wiring mode is as follows: .....	8
4.1 RS485.....	10
4.1 Relay output .....	10
4.1 Digital input .....	10
5 Function.....	11
5.1 Multi tariff .....	11
5..1 Manual control mode .....	11
5..2 RTC control model.....	11
5.1 Demand .....	11
5..1 Calculation method of demand .....	12
5.1 Alarm .....	12
5..1 Alarm output .....	13
5.1 Phase sequence detection.....	13
6 Modbus Communication .....	14
6.1 Modbus-RTU Communication parameters.....	14
6.1 Setting the device address.....	14
6.1 Modbus RTU Data frame .....	15
6.1 PDU Request data format.....	15
6.1 Function code .....	15
6.1 Register list .....	16
6.1 Modbus-RTU Function code operation instructions.....	17
6..1 Operating instructions for function code (0x10=16).....	17
6..2 Function code (0x03=3) Operating instructions .....	19
6..3 Error response .....	20
7 List of configuration instructions .....	21
7.1 System parameter setting.....	21
7.1 Parameter setting of phase L1L2L3 current transformer .....	21
7.1 Parameter setting of N-phase current transformer .....	22
7.1 Phase L1L2L3 Current direction setting .....	22
7.1 Phase L1L2L3 Current channel setting.....	23
7.1 Zero drift suppression setting.....	23
7.1 Demand parameter setting.....	23
7.1 Tariff mode setting.....	24
7.1 Manual tariff setting .....	24

7.1 RTC Tariff time period setting .....	24
7.1 RTC Tariff selection setting .....	25
7.1 Equipment time setting .....	25
7.1 Communication parameter setting.....	26
7.1 Reset.....	26
7.1 Relay output control mode .....	26
7.1 Relay output manual control .....	27
7.1 Alarm setting .....	27
<b>8 Register list .....</b>	<b>27</b>
8.1 Modbus Register List.....	28
8.1.1 Equipment parameters .....	28
8.1.2 Communication parameters .....	29
8.1.3 Relay .....	29
8.1.4 Digital input status.....	30
8.1.5 Voltage and current phase sequence.....	30
8.1.6 Configure instruction register .....	30
8.1.7 Power system parameters .....	31
8.1.8 Current direction setting.....	32
8.1.9 Current channel selection .....	32
8.1.10 Zero drift suppression parameters.....	33
8.1.11 Tariff parameters .....	33
8.1.12 Voltage, current, power and power factor.....	34
8.1.13 Electric energy .....	36
8.1.14 Tariff energy .....	37
8.1.15 Demand parameters .....	38
8.1.16 Voltage and current harmonics.....	40
8.1.17 Max and min value .....	42
8.1.18 Unbalance.....	44
8.1.19 Current K factor .....	44
8.1.20 Voltage and current angle.....	45
8.1.21 Alarm .....	45
<b>9 Revision History .....</b>	<b>52</b>

---

## 1 Product description



ME131 multi-circuit smart energy meter supports three-phase three-wire and three-phase four-wire systems. It can measure multi electrical parameters such as current, voltage, power factor, harmonic, power and energy of electric network phase L1, L2 and L3.

With standard configuration of RS485 communication interface and standard Modbus-RTU protocol, ME131 is compatible with various configuration systems and could transmit the electrical parameters collected by the front end to the system data center in real time.

Description	
Mounting type	Din Rail
Model No.	Master meter: ME131M, Submeter: ME131S
Type of current sensor	Rogowski coil Voltage-output current transformer
Feature	Directly connect to Rogowski coil
Advantage	Wide current range, measurement without dismantling
Wiring system	3P4W_3CT, 3P3W_3CT, 3P3W_2CT, 1P3W, 1P2W
Application field	Power analysis and energy consumption monitoring
Display screen	None
Weight	ME131M: 122g; ME131S: 59g
Dimension	ME131M: L*W*D 9.3*8.0*3.6CM; ME131S: L*W*D 9.3*8.0*1.81CM
Color	White
Current measurement	
Channel input voltage range	0-900mVAC peak, 636 mV RMS
Measurement range	Different current sensors have different measuring ranges
Rogowski coil	50mV/kA@50Hz(0-12000A), @60Hz(0-10000A) 85mV/kA@50Hz(0-7000A), @60Hz(0-6000A) 100mV/kA@50Hz(0-6000A), @60Hz(0-5000A) ...
Voltage-output CT	0~99999A
Voltage measurement	
Measurement range	0~600VAC
Maximum measured value	720VAC
Digital signal	
Switching output	1-circuit electromagnetic relay output, contact capacity: 3A 30V DC, 3A 250V AC
Switching value input	Optocoupler isolation (5kVrms)
Communication	
RS485 Communication	One RS485 communication interface Interface type: two-wire half-duplex Communication baud rate: 2400bps~38400bps Protocol: Modbus-RTU
Power supply	
Power supply	85~265VAC/110~370VDC, 45~60Hz (24V DC power supply version could be customized)

Maximum power consumption	$\leq 3.5VA$
---------------------------	--------------

## 2 Measurement parameters

Instantaneous value	
Phase Voltage	U1, U2, U3, AVG, U0 (Zero sequence voltage)
Line Voltage	U12, U23, U31, AVG
Current	I1, I2, I3, AVG, In
Grid frequency	F1, F2, F3, $\Sigma$
Power factor PF	PF1, PF2, PF3, $\Sigma$
Fundamental power factor DPF	DPF1, DPF2, DPF3, $\Sigma$
Active power	P1, P2, P3, $\Sigma$
Reactive power	Q1, Q2, Q3, $\Sigma$
Apparent power	S1, S2, S3, $\Sigma$
Energy	
Active energy Pos.	EP1, EP2, EP3, $\Sigma$
Active Energy Neg.	EP1, EP2, EP3, $\Sigma$
Reactive Energy Pos.	EQ1, EQ2, EQ3, $\Sigma$
Reactive energy Neg.	EQ1, EQ2, EQ3, $\Sigma$
Apparent Energy	ES1, ES2, ES3, $\Sigma$
Tariff Energy	ET1, ET2, ET3, ET4, ET5, ET6
Harmonics	
Voltage Harmonic Distortion	Total harmonic (U1, U2, U3) Odd total harmonic (U1, U2, U3) Even total harmonic (U1, U2, U3) Sub-harmonic 1-50th (U1, U2, U3)
Current Harmonic Distortion	Total harmonic (I1, I2, I3) Odd total harmonic (I1, I2, I3) Even total harmonic (I1, I2, I3) K-factor (I1, I2, I3) Sub-harmonic 1-50th (I1, I2, I3)
Voltage Harmonic Value	Total harmonic (U1, U2, U3) Sub-harmonic 1-50th (U1, U2, U3)
Current Harmonic Value	Total harmonic (I1, I2, I3) Sub-harmonic 1-50th (I1, I2, I3)
Phase	
Phase sequence	Voltage, Current
Voltage angle	U1, U2, U3
Current angle	I1, I2, I3
Voltage-current angle	UI1, UI2, UI3
Demand	
Demand	Total active power, total reactive power, total apparent power

Maximum demand of total active power	Maximum demand and time
Maximum demand of total reactive power	Maximum demand and time
Maximum demand of total apparent power	Maximum demand and time
<b>Unbalance</b>	
Voltage unbalance	Negative Sequence, zero Sequence
Current unbalance	Negative Sequence, zero Sequence
<b>Max. &amp; Min.</b>	
Phase Voltage	Each phase and average
Line Voltage	Each phase and average
Current	Each phase and average
Active power	Each phase and total
Reactive power	Each phase and total
Apparent power	Each phase and total

### 3 Accuracy and certification

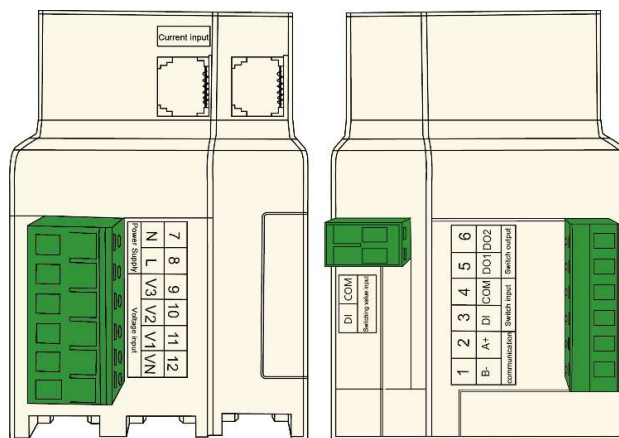
<b>Measurement Accuracy</b>	
Current measurement accuracy	0.1%+ Current sensor accuracy
Voltage measurement accuracy	± 0.2%(60V~600V AC)
Grid frequency	± 0.01%(45~65Hz)
Power factor	± 0.005
Active and apparent power	IEC62053-22 class 0.5S
Reactive power	IEC62053-21 class 1S
Active energy	IEC62053-22 class 0.5S
Reactive energy	IEC62053-21 class 1S
<b>Environment condition</b>	
Operating temperature	-25°C~+60°C
Storage temperature	-40°C~+85°C
Humidity range	5~95% RH, 50°C (non-condensing)
Class of pollution	2
Overvoltage capacity	III, Applicable to power distribution system below 277/480VAC
Insulation strength	IEC61010-1
Altitude	3000m Max
Anti-pollution grade	IP20 (Meet the standard of IEC 60629)
Quality guarantee	12 months
<b>EMC (Electromagnetic compatibility)</b>	
Electrostatic discharge	Level IV(IEC61000-4-2)
Radiated immunity	Level III (IEC61000-4-3)
EFT Electrical fast burst immunity	Level IV (IEC61000-4-4)
Surge immunity	Level IV (IEC61000-4-5)
Conducted disturbance immunity	Level III (IEC61000-4-6)



Power frequency magnetic field immunity	0.5mT (IEC61000-4-8)
Conduction and radiation	Class B (EN55022)
<b>Measurement standard</b>	
EN 62052-11, EN61557-12, EN 62053-21, EN 62053-22, EN 62053-23, EN 50470-1, EN 50470-3, EN 61010-1, EN 61010-2, EN 61010-031	

## 4 Connection

The energy meter is equipped with standard interface and convenient RJ12 interface to meet different functional requirements



Interface number	Interface name	Interface definition	Interface type	Remarks
1	B-	RS485 Communication B	Communication	RS485 communication
2	A+	RS485 Communication A		
3	DI	Digital input +	Switching value input	Digital input
4	COM	Digital input -		
5	DO1	Digital output 1	Switching output	One relay output, normally open contact
6	DO2	Digital output 2		
7	N	Power supply (-)	Power supply 85~265VAC	Power supply 85~265VAC, 45~60Hz 110~370VDC
8	L	Power supply (+)		

				(24V DC version could be customized)
9	V3	Phase L3 Voltage input	Voltage input	Measuring voltage input channel
10	V2	Phase L2 Voltage input		
11	V1	Phase L1 Voltage input		
12	VN	Phase N Voltage input		

## 4.1 Power supply

The energy meter adopts external power supply, without internal direct power supply. The voltage range is: 85~265VAC/110~370VDC, 45~60Hz, maximum power consumption 3.5VA (24V DC version could be customized)

- Do not connect the meter when the cable is live.
- Before connecting the power supply, make sure that the power supply voltage is within the required range, otherwise the meter cannot work normally.

## 4.1 Voltage and current input

Energy meter supports wiring mode, three-phase four-wire\_3CT(3P4W\_3CT), three-phase three-wire\_3CT(3P3W\_3CT), three-phase three-wire\_2CT(3P3W\_2CT), one-phase three-wire(1P3W), one phase and two-wire(1P2W)

- The actual wiring mode of the meter must be consistent with the wiring mode configured inside the meter.
- Three-phase four-wire 3CT (3P4W\_3CT) requires three current sensors, and the N-phase current is obtained through calculation.
- Three-phase three-wire 3CT (3P3W\_3CT) requires three current sensors, and phase B current is measured by the sensor.
- Three-phase three-wire 2CT (3P3W\_2CT) requires two current sensors, phase B current is obtained through calculation.
- The phase sequence of voltage and current must follow the phase sequence of L1L2L3, otherwise the meter will display voltage and current phase sequence error.
- When using the current sensor, note that the direction of the current arrow on the sensor must be consistent with the actual current direction, that is, the sensor current arrow points to the load end.

### 4..1 Set current input parameter:

Rogowski coil:

Parameter name	Description
Rcoil Pri	Rated current value of primary side (input current of Rogowski coil)

Rcoil Sec	Secondary output value (Rogowski coil output value)
Rated Current	Nominal current
<p>Example: Coil Ratio is 85mV/kA@50Hz  Rcoil Sec=85mV  When measure 1000A, set nominal current =1000A  When measure 1500A, set nominal current =1500A  When measure 100A, to ensure high accuracy, set the nominal current =100A</p>	
<b>If change coils with different ratio, the ratio should be reset.</b>	

Current transformer:

Parameter name	Description
CT Pri	Rated current value of primary side (CT input current)
CT Sec	Secondary output value (CT output value)
Rated Current	Nominal current
<p>Example: CT Ratio is 500A/333mV  CT Pri =500A, CT Sec=333mV</p>	
<b>If change CT with different ratio, the ratio should be reset.</b>	

## 4.2 Test version software

### Meter calibration

ME131 Test version of computer software

Calibration Read data SET Description

Read meter parameters

Wiring mode:  Frequency (Hz):  Nominal voltage (V):  VT Ratio:  CT Ratio:

IABC sensor:  IABC Pri(A):  IABC Sec(mV):  IABC Range(A):

IN sensor:  IN Pri(A):  IN Sec(mV):  IN Range(A):

Read meter parameters

Write meter parameters

Grid parameters

Wiring mode:  Sensor:  Sensor:

Frequency:  Rcoil Pri(A):  Rcoil Pri(A):

Nominal voltage (V):  Rcoil Sec(mV)@50Hz:  Rcoil Sec(mV)@50Hz:

VT Ratio:  Rcoil Range(A):  Rcoil Range(A):

CT Ratio:  VCT Pri(A):  VCT Pri(A):

VCT Sec(mV):  VCT Sec(mV):

VCT Range(A):  VCT Range(A):

SET SET SET

Calibrate meter

Calibration value:  Calibration type:  Calibration phase:

Calibrate mete Reset calibration

## Electricity meter setting

ME131 Test version of computer software

Calibration Read data SET Description

Communication parameter setting

Device address: 1 Baud rate: 2400 Parity check: None Stop bit: 1bit

Product parameters

Model No.: ME131 Serial No.: 2522001001

Set time:  Reset:

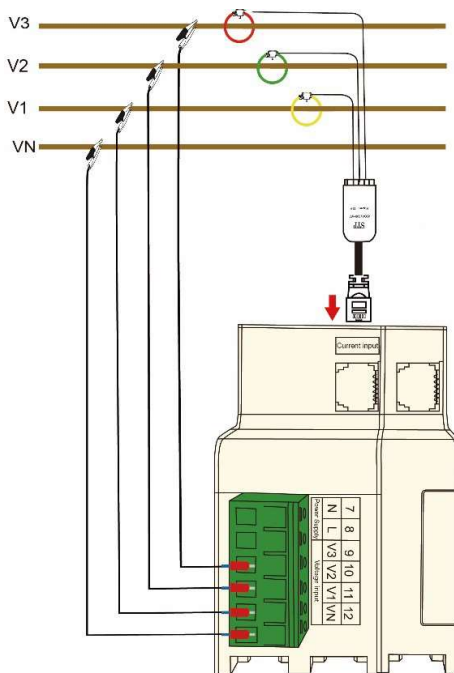
Zero drift suppression: Voltage threshold: 0.10 Current threshold: 0.1  Set relay output:  Close  Break off

Standard value

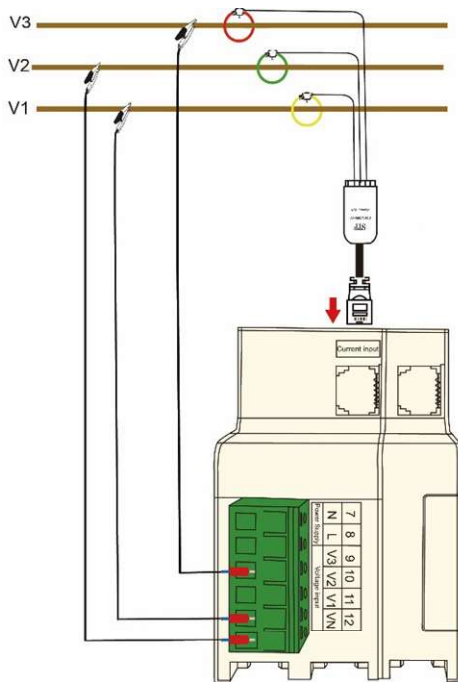
	Voltage	Current	PF	Active power	Reactive power	Apparent power	Frequency
Standard	220.0 V	200.0 A	0.500	22.000 Kw	38.105 kVar	44.000 kVa	50.000 Hz
Error	0.200 %	0.500 %	0.005 %	0.500 %	0.500 %	0.500 %	0.005 Hz

4.3 Voltage and current wiring mode is as follows:

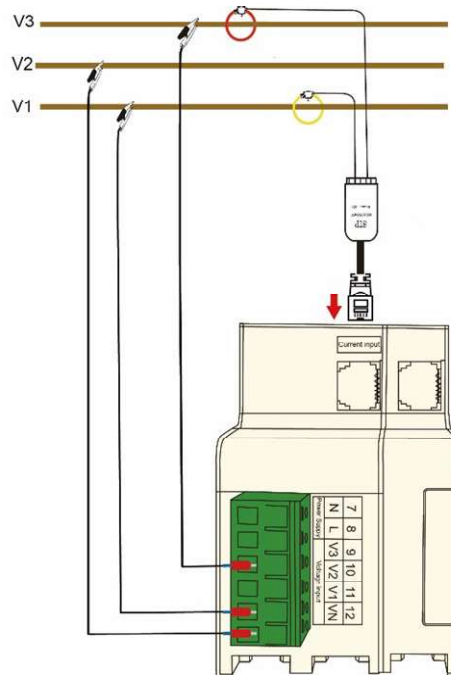
### Three-phase four-wire 3CT



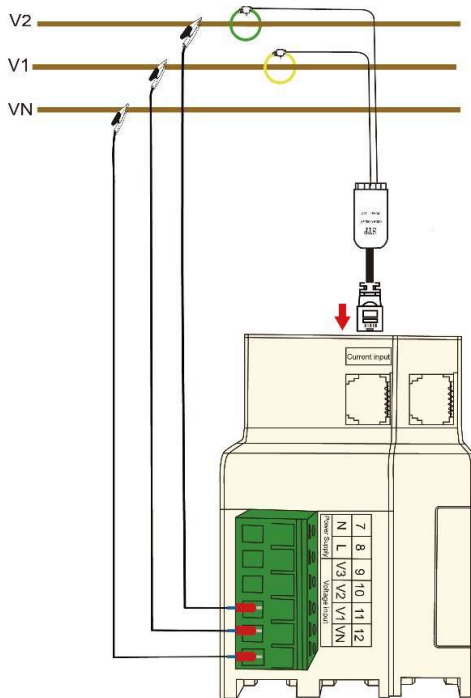
**Three-phase three-wire 3CT**



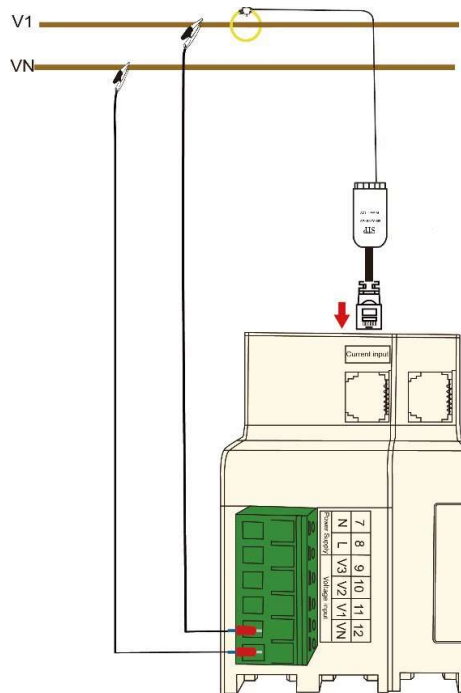
**Three-phase three-wire2CT**



**One-phase three-wire**

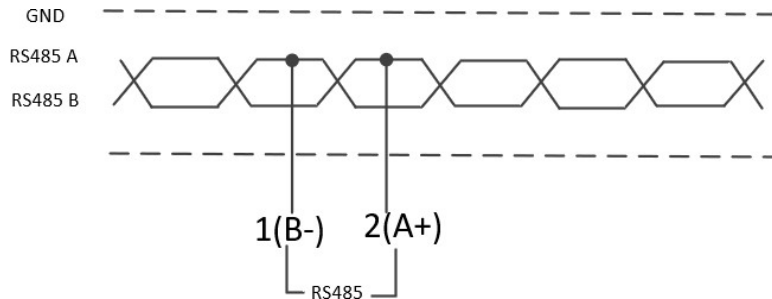


**One phase and two-wire**



## 4.1 RS485

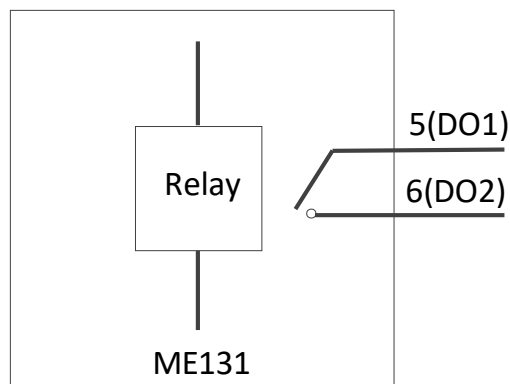
The meter is equipped with one RS485 communication interface, which supports ModBus-RTU protocol. The RS485 communication interface requires shielded twisted pair connection and daisy chain connection. In case of long distance and high speed, a 120  $\Omega$  resistance is required to be connected in parallel at both ends of the daisy chain.



## 4.1 Relay output

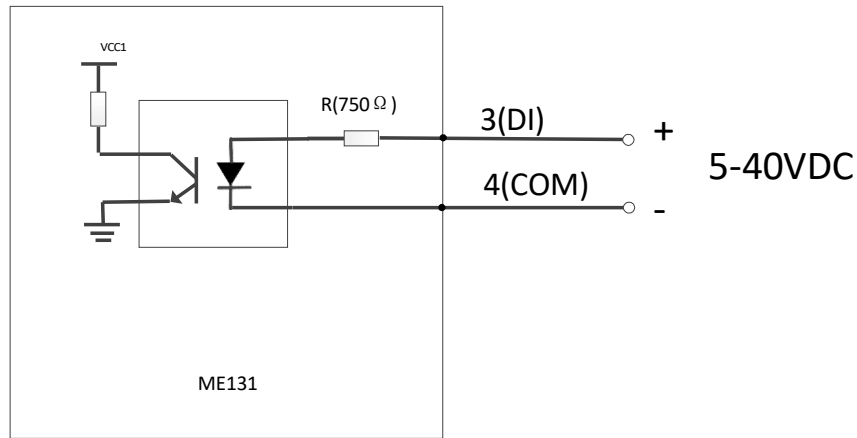
The meter is equipped with a relay output, which is a normally open contact. The terminal blocks are identified as R1 and R0, where R0 is the common contact and R1 is the normally open contact. Maximum load capacity of relay: 3A 30V DC, 3A 250V AC. The closed state of the normally open contact of the relay can be read through Modbus. There are two relay output control modes, which can be modified through Modbus

Relay output control mode	Description
Manual mode	Control relay output via Modbus
Alarm mode	Control the relay output through setting alarm parameters



## 4.1 Digital input

The meter is equipped with a digital switching input. The terminal block identification is: 3 (DI), 4 (COM). The status of digital switch input can be read through RS485/ModBus protocol.



## 5 Function

### 5.1 Multi tariff

The meter provides multi-tariff electricity accumulation function, supporting up to 6 tariff. There are two switching control modes for tariff, which can be modified through Modbus.

Switching control mode of tariff	Description
Manual mode	Switch tariff through Modbus
RTC mode	Trigger tariff switching through RTC time period

#### 5.1.1 Manual control mode

The tariff can be switched through the configuration command 1071 of Modbus

#### 5.1.2 RTC control model

In RTC control mode, tariff switching is triggered by real-time clock.

The RTC control mode supports 6 time periods (Ta, Tb, Tc, Td, Te, Tf) and 6 tariff (T1, T2, T3, T4, T5, T6). Any tariff can be specified for 6 time periods (Ta, Tb, Tc, Td, Te, Tf).

The time period and target tariff can be modified through Modbus.

The time period is set according to 24 hours, starting from the Ta starting time. The Tc starting time cannot be between the Ta starting time and the Tb starting time, and the Td starting time cannot be between the Ta starting time and the Tc starting time, and so on.

### 5.1 Demand

The energy meter provides active power, reactive power, apparent power demand and maximum demand.

The calculation method and calculation interval of demand can be configured through Modbus.

## 5.1.1 Calculation method of demand

The energy meter supports two demand calculation methods: fixed type and sliding type.

Demand calculation method	Description
Fixed type	The meter will calculate and update the demand at the end of each interval
Sliding type	Update demand every 1 minute

The following figure describes two methods of demand calculation, taking the demand interval of 15 minutes as an example:

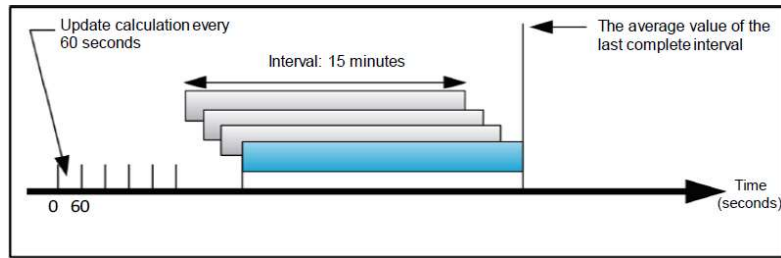


图 5-1 Sliding type

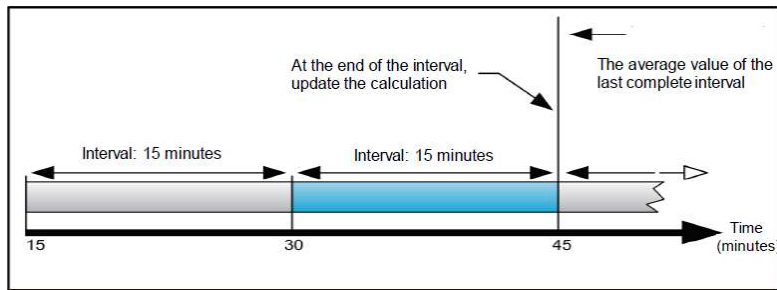


Figure 5-2 Fixed type

## 5.1 Alarm

The meter provides a variety of alarm parameter settings and alarm output, and the alarm parameters can be configured through Modbus.

Alarm type	Description
Over current, each phase	If one phase value exceeds the alarm threshold, an alarm will be generated, When all phases are less than the release threshold, the alarm is released.
Under current, each phase	If one phase value exceeds the alarm threshold, an alarm will be generated, When all phases are greater than the release threshold, the alarm is released.
Over phase voltage, each phase	If one phase value exceeds the alarm threshold, an alarm will be generated, When all phases are less than the release threshold, the alarm is released.



Under phase voltage, each phase	If one phase value exceeds the alarm threshold, an alarm will be generated, When all phases are greater than the release threshold, the alarm is released.
Overline voltage, each phase	If one phase value exceeds the alarm threshold, an alarm will be generated, When all phases are less than the release threshold, the alarm is released.
Underline voltage, each phase	If one phase value exceeds the alarm threshold, an alarm will be generated, When all phases are greater than the release threshold, the alarm is released.
Overpower, total active (absolute value)	
Overpower, total reactive (absolute value)	
Overpower, total apparent	
Overdemand, total active power (absolute value), current	
Overdemand, total reactive power (absolute value), current	
Overdemand, total apparent power, current	
Over THD-U, each phase	If one phase value exceeds the alarm threshold, an alarm will be generated, When all phases are less than the release threshold, the alarm is released.
Over THD-I, each phase	If one phase value exceeds the alarm threshold, an alarm will be generated, When all phases are less than the release threshold, the alarm is released.

## 5.1 Alarm output

Alarm output can be associated with buzzer and relay (relay control mode needs to be configured as alarm mode) output. After the alarm is released, the corresponding output will also be released.

### 5.1 Phase sequence detection

The meter supports three-phase voltage and current phase sequence detection, and can read the phase sequence status through Modbus.

**Note:** The correct phase sequence of voltage and current can only ensure the correct phase sequence of each, and cannot guarantee the corresponding relationship between voltage and current. Therefore, it is necessary to pay attention to the wiring mode.

## 6 Modbus Communication

Communication	
Communication interface	RS485
Communication protocol	Modbus RTU

The standard communication protocol Modbus-RTU is adopted.

### 6.1 Modbus-RTU Communication parameters

Before Modbus-RTU communication, the following parameters need to be set:

Parameter	Effective value	Default
Address	1 - 247	1(via dial switch)
Baud rate	-1200 -2400 -4800 -9600 -19200 -38400	9600
Data bits	8	8
Verification method	- No calibration - odd check - Even check	No calibration
Stop bit	1-2	1

### 6.1 Setting the device address



The device address is set through a 5-bit dial switch, and the maximum settable address is 32.

The device address is calculated by adding the (weight value \* dial status value) of five dials.

#### Tips

- It takes effect immediately after the dial code setting.

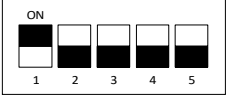
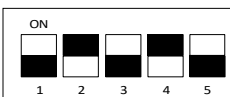
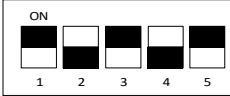
#### Dial status value

Dialing status (Black is the dial code)	Dial status value	Remarks
ON 	1	
ON 	0	

Dial weight value

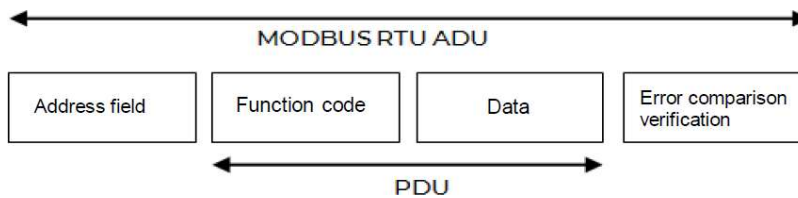
Dial number	Numerical weight	Remark
1	1	
2	2	
3	4	
4	8	
5	16	

Example of setting device address

Dial switch position (Black is the dial code)	Device address	Remark
	The device address is 1, and the calculation is as follows: $1*1+2*0+4*0+8*0+16*0=1$	Factory Default
	The device address is 10, and the calculation is as follows: $1*0+2*1+4*0+8*1+16*0=10$	
	The device address is 21, and the calculation is as follows: $1*1+2*0+4*1+8*0+16*1=21$	

## 6.1 Modbus RTU Data frame

Modbus RTU data frame includes address field, function code, data and error check.



### 6.1 PDU Request data format

Function code	Instructions
8-Bits	$N \times 8\text{-Bits}$

### 6.1 Function code

Function codes are used to indicate how the device processes the command. The following table shows the available function codes and their descriptions.

Function code		Name of function code	Function	Remark
Decimal system	Hexadecimal			
3	03H	Read Holding Register	Used to read device parameters	
16	10H	Write multiple registers	Used to configure device parameters	

## 6.1 Register list

The register list has the following headings:

Register alias	Register address	Operation read/write	Size	Type	Unit	Description
----------------	------------------	----------------------	------	------	------	-------------

- Register alias: It refers to the meaning of register.
- Register address: Address of Modbus data. The data address in this document is in decimal format.
- Operation: indicates the operation that the register can perform, R: read-only; W: Writable; WC: writable through instruction register.
- Size: Indicates the size of 16-bit data.
- Type: The type of data encoding.
- Unit: The unit of the register value.
- Description: Describe the function of this register.

### Data type list:

The following table lists the data types used in this document:

Type	Description	Range
UInt16	Unsigned 16-bit integer	0 - 65535
Int16	Signed 16-bit integer	-32768 - +32767
UInt32	Unsigned 32-bit integer	0 - 4 294 967 295
UInt64	Unsigned 64-bit integer	0 - 18 446 744 073 709 551 615
UTF8	8-bit UTF code	Multibyte Unicode encoding
Float32	32-bit floating point	Standard IEEE floating point data (single precision)
Date Time	Date Time Type	-
Time	Time type	-

Date Time detailed explanation:

Byte	Position															
	15	14	13	12	11	10	9	8	7	6	5	4	3	2	1	0
1	Year (2000 - 2099)															
2	Month (1 - 12)								Date (1 - 31)							
3	Hour (0 - 23)								Minute (0 - 59)							
4	Second (0 - 59)															

Time type details:

Byte	Position														
	15	14	13	12	11	10	9	8	7	6	5	4	3	2	1
1	Hour (0 - 23)														
2	Minute (0 - 59)														
3	Second (0 - 59)														

Configure the device via Modbus-RTU.

You can use function code 16 to write instructions to the device and configure the device parameters.

Device parameter configuration can only be configured by writing the corresponding data to the "configuration instruction register", that is, writing the corresponding data to the address starting from 300 to configure the corresponding parameters.

#### Configuration result:

The configuration result can be read through registers 424 and 425.

Register address	Content	Size (16 bits)	Data (example)
424	Configuration instruction code	1	1001(Set time)
425	Result	1	0 = Effective operation 80 = Invalid instruction code 81 = Invalid command parameter 82 = Numbers of invalid instruction parameters 83 = Operation not performed

## 6.1 Modbus-RTU Function code operation instructions

### 6..1 Operating instructions for function code (0x10=16)

Function code (0x10=16) is used to configure device parameters. Its request and return data format is as follows:

Request data format:

Serial No.	Name	Type	Range (Decimal system)	Description
1	Device address	UInt8	1-247	
2	Function code	UInt8	16	
3	Register start address	UInt16	-	High byte first (send order)
4	Number of registers	UInt16	1-123	High byte first (send order)
5	Number of register bytes	UInt8		Number of registers * 2
6	Write value of register 1	UInt16	-	High byte first (send order)

Serial No.	Name	Type	Range (Decimal system)	Description
7	...	UInt16	-	High byte first (send order)
8	Write value of register n	UInt16	-	High byte first (send order)
9	CRC-16 check code	UInt16	-	Low byte first (send order)

Return data format:

Serial No.	Name	Type	Range (Decimal system)	Description
1	Device address	UInt8	1-247	
2	Function code	UInt8	16	
3	Register start address	UInt16	300	High byte first
4	Number of registers	UInt16	1-123	High byte first
5	CRC-16 Check code	UInt16	-	Low byte first

Attention!

Function code (0x10=16) can only write data to the "configuration instruction register", and can only write data to the register starting from address 300.

For example:

Configure the equipment time (command=1200, set as: 2022-11-1 12:20:00).

Serial No.	Meaning	Type	Value (Decimal system)	Value (Hexadecimal)	Description
1	Device address	UInt8	1	01	
2	Function code	UInt8	16	10	
3	Register start address	UInt16	300	012C	Configuration register start address
4	Number of configuration registers	UInt16	7	0007	Configure time command + parameters 7 registers in total
5	Data length	UInt8	14	0E	Number of configuration registers * 2
6	Register 300 written value	UInt16	1200	04B0	Instruction code for configuring time 1200
7	Register 301 written value	UInt16	2022	07E6	Year=2022
8	Register 302 written value	UInt16	11	000B	Month=11
9	Register 303 written value	UInt16	1	0001	Date=1
10	Register 304 written value	UInt16	12	000C	Hour=12

Serial No.	Meaning	Type	Value (Decimal system)	Value (Hexadecimal)	Description
11	Register 305 written value	UInt16	20	0014	Minute=20
12	Register 306 written value	UInt16	0	0000	Second=0
13	CRC-16 Check code	UInt16	35524	8AC4	Low byte first (send order)

The order of sending bytes is as follows:

01 10 01 2C 00 07 0E 04 B0 07 E6 00 0B 00 01 00 0C 00 14 00 00 C4 8A

If the configuration data is correct, the following data will be returned:

01 10 01 2C 00 07 41 FE

Serial No.	Name	Type	Range(Hexadecimal)	Range(Decimal system)
1	Device address	UInt8	01	1
2	Function code	UInt8	10	16
3	Register start address	UInt16	012C	300
4	Number of registers	UInt16	0007	7
5	CRC-16 Check code	UInt16	41FE	

## 6.2 Function code (0x03=3) Operating instructions

Function code (0x03=3) is used to read the device register parameters. Its request data and return data format are as follows:

Request data format:

Serial No.	Name	Type	Range(Decimal system)	Description
1	Device address	UInt8	1-247	
2	Function code	UInt8	3	
3	Start register address	UInt16	-	High byte first (send order)
4	Number of registers	UInt16	1-125	High byte first (send order)
5	CRC-16 check	UInt16	-	Low byte first (send order)

Return data format:

Serial No.	Name	Type	Range(Decimal system)	Description
1	Device address	UInt8	1-247	
2	Function code	UInt8	3	
3	Read register bytes	UInt8	-	Number of read registers * 2
4	Value of register 1		-	High byte first
5	...		-	High byte first
6	Value of register n		-	High byte first
7	CRC-16 check	UInt16	-	Low byte first

Example:

Read the voltage values of L1, L2 and L3 (the starting address of voltage register is: 1010):

Serial No.	Name	Type	Range(Decimal system)	Range(Hexadecimal)	Description
1	Device address	UInt8	1	0x01	
2	Function code	UInt8	3	0x03	
3	Start register address	UInt16	1010	0x03F2	
4	Number of registers	UInt16	6	0x0006	
5	CRC-16 check	UInt16	32612	0x7F64	Low byte first (send order)

The order of sending bytes is as follows:

01 03 03 F2 00 06 64 7F

Return data:

01 03 0C 43 5C 00 00 43 5D 00 00 43 5E 00 00 14 AC

Serial No.	Name	Type	Hexadecimal	Decimal system
1	Device address	UInt8	01	1
2	Function code	UInt8	03	3
3	Read register bytes	UInt8	0C	12
4	Phase L1 voltage	float32	435C0000	220V
5	Phase L2 voltage	float32	435D0000	221V
6	Phase L3 voltage	float32	435E0000	222V
7	CRC-16 check	UInt16	14AC	

### 6..3 Error response

Error response data format:

Serial No.	Name	Type	Decimal system	Hexadecimal	Remark
1	Device address	UInt8	1-247	0x01-0xF7	
2	Function code	UInt8	(128+3) (128+16)	(0x80+0x03) (0x80+0x10)	
3	Error code	UInt8			
4	CRC-16 check	UInt16			Low byte first

Modbus Error code:

Code	Name	Meaning
0x01	Illegal function code	The function code 3 or 16 supported by the device is not used
0x02	Illegal data address	The register data written or read is not within the address range supported by the device
0x03	Illegal data value	The data value written to the register does not meet the requirements
0x04	Equipment error	An unknown error occurred



## 7 List of configuration instructions

### 7.1 System parameter setting

Instruction code	Operation	Size	Type	Unit	Range (Decimal system)	Description
1001	W	1	UInt16	-	1,2,3,4,5	Wiring mode 1=3P4W_3CT 2=3P3W_3CT 3=3P3W_2CT 4=1P3W 5=1P2W
	W	1	UInt16	Hz	50,60	Grid frequency
	W	1	UInt16	V	1-65535	Nominal voltage (excluding VT ratio)
	W	2	UInt32	-	1-99999999	VT transformation ratio, amplification 10000 times
	W	2	UInt32	-	1-99999999	CT transformation ratio, magnification 10000 times

### 7.1 Parameter setting of phase L1L2L3 current transformer

Instruction code	Operation	Size	Type	Unit	Range (Decimal system)	Description
1002	W	1	UInt16	-	0,1	Phase L1L2L3 current access mode 0 = Rogowski coil input 1 = VCT input
	W	2	UInt32	A	1-999999	Phase L1L2L3 Rogowski coil input value
	W	2	UInt32	mV@50 Hz mV@60 Hz	1-999999	Phase L1L2L3 Rogowski coil output value =Actual value*100 <b>(Note: the output shall be set according to the grid frequency)</b>
	W	2	UInt32	A	1-999999	Phase L1L2L3 Rogowski coil nominal current
	W	2	UInt32	A	1-999999	PHASE L1L2L3 VCT input value
	W	2	UInt32	mV	1-999999	PHASE L1L2L3 VCT output value =Actual value*100

Instruction code	Operation	Size	Type	Unit	Range (Decimal system)	Description
	W	2	UInt32	A	1-999999	PHASE L1L2L3VCT nominal current

## 7.1 Parameter setting of N-phase current transformer

Instruction code	Operation	Size	Type	Unit	Range (Decimal system)	Description
1003	W	1	UInt16	-	0,1	N-phase current access mode 0 = Rogowski coil input 1 = VCT input
	W	2	UInt32	A	1-999999	N-phase Rogowski coil input value
	W	2	UInt32	mV@50 Hz mV@60 Hz	1-999999	N-phase Rogowski coil output value =Actual value*100 <b>(Note: the output shall be set according to the grid frequency)</b>
	W	2	UInt32	A	1-999999	N-phase Rogowski coil nominal current
	W	2	UInt32	A	1-999999	N-phase VCT input value
	W	2	UInt32	mV	1-999999	N-phase VCT output value =Actual value*100
	W	2	UInt32	A	1-999999	N-phase VCT nominal current

## 7.1 Phase L1L2L3 Current direction setting

This configuration can be used to modify the current direction when the coil direction is inconsistent with the actual one.

Instruction code	Operation	Size	Type	Unit	Range (Decimal system)	Description
1010	W	1	UInt16	-	0,1	Phase L1 current direction 0 = Positive (default) 1 = Reverse
	W	1	UInt16	-	0,1	L2 current direction 0 = Positive (default) 1 = Reverse
	W	1	UInt16	-	0,1	L3 current direction 0 = Positive (default) 1 = Reverse

## 7.1 Phase L1L2L3 Current channel setting

When the current and voltage do not correspond, you can use this configuration to modify the current channel selection so that the current and voltage correspond to each phase.

Instruction code	Operation	Size	Type	Unit	Range (Decimal system)	Description
1011	W	1	UInt16	-	0, 1, 2	L1 current channel selection 0 = Current channel 1 (default) 1 = Current channel 2 2 = Current channel 3
	W	1	UInt16	-	0, 1, 2	L2 current channel selection 0 = Current channel 1 1 = Current channel 2 (default) 2 = Current channel 3
	W	1	UInt16	-	0, 1, 2	L3 current channel selection 0 = Current channel 1 1 = Current channel 2 2 = Current channel 3 (default)

## 7.1 Zero drift suppression setting

Instruction code	Operation	Size	Type	Unit	Range (Decimal system)	Description
1020	W	1	UInt16	%	0~1000	Voltage zero drift suppression takes (nominal voltage * VT ratio) as reference = Actual value *100 Default: 10
	W	1	UInt16	%	0~1000	Current zero drift suppression takes (nominal current * CT ratio) as reference. =Actual value*100 Default: 10

## 7.1 Demand parameter setting

Instruction code	Operation	Size	Type	Unit	Range (Decimal system)	Description
1060	W	1	UInt16	-	0,1	Demand calculation method 0 = Fixed type 1 = Sliding type
	W	1	UInt16	Minute	1-60	Demand calculation interval

## 7.1 Tariff mode setting

Instruction code	Operation	Size	Type	Unit	Range (Decimal system)	Description
1070	W	1	UInt16	-	0,1	Tariff switching mode 0 = Manual switching 1 = RTC switching

## 7.1 Manual tariff setting

Instruction code	Operation	Size	Type	Unit	Range (Decimal system)	Description
1071	W	1	UInt16	-	0-5	Manual tariff setting 0 = tariff 1 1 = tariff 2 ... 5 = tariff 6 <i>(Note: this setting is only valid when the tariff mode is manual switching)</i>

## 7.1 RTC Tariff time period setting

Instruction code	Operation	Size	Type	Unit	Range (Decimal system)	Description
1072	W	3	Time	-	-	Ta Start time
	W	3	Time	-	-	Tb Start time
	W	3	Time	-	-	Tc Start time
	W	3	Time	-	-	Td Start time
	W	3	Time	-	-	Te Start time
	W	3	Time	-	-	Tf Start time

## 7.1 RTC Tariff selection setting

Instruction code	Operation	Size	Type	Unit	Range (Decimal system)	Description
1073	W	1	UInt16	-	0-5	Ta Tariff setting 0 = Tariff 1 1 = Tariff 2 ... 5= Tariff 6
	W	1	UInt16	-	0-5	Tb Tariff setting
	W	1	UInt16	-	0-5	Tc Tariff setting
	W	1	UInt16	-	0-5	Td Tariff setting
	W	1	UInt16	-	0-5	Te Tariff setting
	W	1	UInt16	-	0-5	Tf Tariff setting

## 7.1 Equipment time setting

Instruction code	Operation	Size	Type	Unit	Range (Decimal system)	Description
1200	W	1	UInt16	-	2000-2099	Year
	W	1	UInt16	-	1-12	Month
	W	1	UInt16	-	1-31	Date
	W	1	UInt16	-	0-23	Hour
	W	1	UInt16	-	0-59	Minute
	W	1	UInt16	-	0-59	Second

## 7.1 Communication parameter setting

Instruction code	Operation	Size	Type	Unit	Range (Decimal system)	Description
1210	W	1	UInt16	-	1-247	Slave address
	W	1	UInt16	-	0-4	Baud rate 0 = 2400 1 = 4800 2 = 9600 3 = 19200 4 = 38400
	W	1	UInt16	-	0, 1, 2	Parity check 0 = No verification 1 = Odd check 2 = Even check
	W	1	UInt16	-	0, 1	Stop bit 0 = 1bit 1 = 2bit

## 7.1 Reset

Instruction code	Operation	Size	Type	Unit	Range (Decimal system)	Description
1301	W	1	UInt16	-	1-5	1: Reset Max & Min value 2 : Reset Max demand 3: Reset tariff energy 4: Reset energy 5: Reset all above values

## 7.1 Relay output control mode

Instruction code	Operation	Size	Type	Unit	Range (Decimal system)	Description
2000	W	1	UInt16	-	0-1	Relay output control mode 0 = Manual control mode 1 = Alarm output control mode

## 7.1 Relay output manual control

Instruction code	Operation	Size	Type	Unit	Range (Decimal system)	Description
2001	W	1	UInt16	-	0-1	Relay output control 0 = Relay output open circuit 1 = Relay output closed  <i>(Note: this setting is only valid when the relay output control mode is manual control mode)</i>

## 7.1 Alarm setting

Instruction code	Operation	Size	Type	Unit	Range (Decimal system)	Description
3000	W	1	UInt16	-	-	Alarm ID
	W	1	UInt16	-	0,1	Alarm function 0=Disable 1=Enable
	-	1	UInt16	-	-	Save
	W	2	Float32	-	0-1000000	Alarm activation threshold
	W	2	Float32	%	-	Alarm release point Percentage error relative to alarm activation threshold <i>Example:</i> <i>Overcurrent alarm activation threshold=100A</i> <i>Alarm release point =5%</i> <i>When the current value is less than 100-100 * 5%=95A, the alarm is released</i>
	W	1	UInt16	-	0,1	Buzzer output correlation 0= No correlation 1= Correlation
W	1	UInt16	-	0,1	Relay output correlation 0= No correlation 1= Correlation	

## 8 Register list

The register list has the following headings:

Register alias	Register address	Operation read/write	Size	Type	Unit	Description
----------------	------------------	----------------------	------	------	------	-------------

- Register alias: Used to refer to the meaning of register
- Register address: The starting address of the modbus communication register. It is in **decimal format**, and **the address is the real address without offset**.
- Operation: Indicate the operations that the register can do. R: Readable; W: Can be written directly through 16 function codes; WC: The current register needs to be configured indirectly by writing configuration data to the address starting from instruction register 300
- Size: Indicates how many modbus registers are occupied. One modbus register is 16bit
- Type: Refer to the data type table for the type of data code
- Unit: Unit of register value
- Description: Describe the function of this register

Data type table

Type	Description	Range
UInt16	Unsigned 16-bit integer	0~65535
Int16	Signed 16-bit integer	-32768~+32767
UInt32	Unsigned 32-bit integer	0~4294967295
UInt64	Unsigned 64-bit integer	0~18446744073709551615
Int64	Signed 64-bit integer	-9223372036854775808 ~ 9223372036854775808
UTF8	8-bit UTF code	Multibyte Unicode encoding
Float32	32-bit floating point	Standard IEEE floating point data (single precision)
Date Time	Time type	-

Date Time format:

Byte	Position															
	15	14	13	12	11	10	9	8	7	6	5	4	3	2	1	0
1	Year (2000 - 2099)															
2	Month (1 - 12)								Date (1 - 31)							
3	Hour (0 - 23)								Minute (0 - 59)							
4	Second (0 - 60)															

## 8.1 Modbus Register List

### 8..1 Equipment parameters

Register alias	Register start address (Decimal system)	Operation Read/Write	Size	Type	Unit	Description
Equipment model	60	R	10	UTF8	-	
Serial No.	70	R	2	UInt32	-	
APP Version No.	72	R	1	UInt16	-	Format: X.Y
Date and time	75	R/WC	4	Date time	-	Reg.75: Year 2000-2099 Reg.76: Month (b15:b8),



Register alias	Register start address (Decimal system)	Operation Read/Write	Size	Type	Unit	Description
						Date (b7:b0) Reg. 77: Hour (b15:b8), Minute (b7:b0) Reg. 78: Second

## 8..2 Communication parameters

Register alias	Register start address (Decimal system)	Operation Read/Write	Size	Type	Unit	Description
Slave address	80	R/WC	1	UInt16	-	1-247
Baud rate	81	R/WC	1	UInt16	-	0=2400 1=4800 2=9600 3=19200 4=38400
Verification method	82	R/WC	1	UInt16	-	0 = No verification 1 = Odd check 2 = Even check
Stop bit	83	R/WC	1	UInt16	-	0 = 1 bit 1 = 2 bit

## 8..3 Relay

Register alias	Register start address (Decimal system)	Operation Read/Write	Size	Type	Unit	Description
Output control mode	200	R/WC	1	UInt16	-	Relay output control mode 0 =Manual control mode 1 = Alarm output control mode
Relay output control	201	R/WC	1	UInt16	-	Relay output control 0 = Relay output open circuit 1 = Relay output closed <b>(Note: this setting is only valid when the relay output control mode is manual control mode)</b>
Relay output status	202	R	1	UInt16	-	Relay output status 0 = open circuit 1 = closed

## 8.4 Digital input status

Register alias	Register start address (Decimal system)	Operation Read/Write	Size	Type	Unit	Description
Digital input status	210	R	1	UInt16	-	0 = Digital input open circuit 1 = Digital input closed

## 8.5 Voltage and current phase sequence

Register alias	Register start address (Decimal system)	Operation Read/Write	Size	Type	Unit	Description
Voltage and current phase sequence	220	R	1	UInt16	-	0 = Voltage phase sequence <b>correct</b> , Current phase sequence <b>correct</b> 1 = Voltage phase sequence <b>error</b> , Current phase sequence <b>correct</b> 2 = Voltage phase sequence <b>correct</b> , Current phase sequence <b>error</b> 3 = Voltage phase sequence <b>error</b> , Current phase sequence <b>error</b>

Note: When the current is less than 1% of the nominal current, the current phase sequence may display errors.

## 8.6 Configure instruction register

Register alias	Register start address (Decimal system)	Operation Read/Write	Size	Type	Unit	Description
Instruction code	300	R/W	1	UInt16	-	
Command parameters 001	301	R/W	1	UInt16	-	
Command parameters 002	302	R/W	1	UInt16	-	
...	...	R/W	1	UInt16	-	
Command parameters 123	423	R/W	1	UInt16	-	
Configuration instruction code	424	R	1	UInt16	-	

Register alias	Register start address (Decimal system)	Operation Read/Write	Size	Type	Unit	Description
Configuration results	425	R	1	UInt16	-	0 = Effective operation 80 = Invalid instruction code 81 = Invalid command parameter 82 = Number of invalid instruction parameters 83 = Operation not performed

## 8.7 Power system parameters

Register alias	Register start address (Decimal system)	Operation Read/Write	Size	Type	Unit	Description
Wiring mode	500	R/WC	1	UInt16	-	0= Three-phase four-wire 4CT 1= Three-phase four-wire 3CT 2= Three-phase three-wire 3CT 3= Three-phase three-wire 2CT 4= One-phase three-wire 5= One phase and two-wire
Grid frequency	501	R/WC	1	UInt16	Hz	
Nominal voltage	502	R/WC	1	UInt16	V	Excluding VT ratio
VT Ratio	503	R/WC	2	UInt32	-	Actual value=Read value/10000
CT Ratio	505	R/WC	2	UInt32	-	Actual value=Read value/10000
<b>PHASE L1L2L3 Current transformer</b>						
PHASE L1L2L3 Current access mode	510	R/WC	1	UInt16	-	0 = Rogowski coil 1 = VCT
PHASE L1L2L3 Rogowski coil Pri	511	R/WC	2	UInt32	A	
PHASE L1L2L3 Rogowski coil Sec	513	R/WC	2	UInt32	mV@50 Hz mV@60 Hz	Actual value=Read value/100
PHASE L1L2L3 Rogowski coil Nominal current	515	R/WC	2	UInt32	A	
PHASE L1L2L3 VCT Pri	517	R/WC	2	UInt32	A	
PHASE L1L2L3 VCT Sec	519	R/WC	2	UInt32	mV	Actual value=Read value/100

Register alias	Register start address (Decimal system)	Operation Read/Write	Size	Type	Unit	Description
PHASE L1L2L3 VCT Nominal current	521	R/WC	2	UInt32	A	
<b>N-phase Current transformer</b>						
N-phase Current access mode	530	R/WC	1	UInt16	-	0 = Rogowski coil 1 = CT
N-phase Rogowski coil Pri	531	R/WC	2	UInt32	A	
N-phase Rogowski coil Sec	533	R/WC	2	UInt32	mV@50 Hz mV@60 Hz	Actual value=Read value/100
N-phase Rogowski coil Nominal current	535	R/WC	2	UInt32	A	
N-phase VCT Pri	537	R/WC	2	UInt32	A	
N-phase VCT Sec	539	R/WC	2	UInt32	mV	Actual value=Read value/100
N-phase VCT Nominal current	541	R/WC	2	UInt32	A	

## 8.8 Current direction setting

Register alias	Register start address (Decimal system)	Operation Read/Write	Size	Type	Unit	Description
Phase L1 current direction	550	R/WC	1	UInt16	-	Phase L1 current direction 0=Positive (default) 1=Reverse
Phase L2 current direction	551	R/WC	1	UInt16	-	Phase L2 current direction 0=Positive (default) 1=Reverse
Phase L3 current direction	552	R/WC	1	UInt16	-	Phase L3 current direction 0=Positive (default) 1=Reverse

## 8.9 Current channel selection

Register alias	Register start address (Decimal system)	Operation Read/Write	Size	Type	Unit	Description
Phase L1 current channel	553	R/WC	1	UInt16	-	Phase L1 current channel 0=Channel 1 (Default) 1=Channel 2 2=Channel 3

Register alias	Register start address (Decimal system)	Operation Read/Write	Size	Type	Unit	Description
Phase L2 current channel	554	R/WC	1	UInt16	-	Phase L2 current channel 0=Channel 1 1=Channel 2 (Default) 2=Channel 3
Phase L3 current channel	555	R/WC	1	UInt16	-	Phase L3 current channel 0=Channel 1 1=Channel 2 2=Channel 3 (Default)

### 8.10 Zero drift suppression parameters

Register alias	Register start address (Decimal system)	Operation Read/Write	Size	Type	Unit	Description
Voltage zero drift suppression	600	R/WC	1	UInt16	%	Voltage zero drift suppression takes (nominal voltage * VT ratio) as reference Actual value=Read value/100
Current zero drift suppression	601	R/WC	1	UInt16	%	Current zero drift suppression takes (nominal current * CT ratio) as reference Actual value=Read value/100

### 8.11 Tariff parameters

Register alias	Register start address (Decimal system)	Operation Read/Write	Size	Type	Unit	Description
Current tariff	800	R	1	UInt16	-	Current tariff 0-5=tariff 1-tariff 6
Tariff switching mode	801	R/WC	1	UInt16	-	Tariff switching mode 0= Manual switching 1=RTC switching
Manual tariff selection	802	R/WC	1	UInt16	-	Manual tariff selection 0-5=Tariff 1-Tariff 6
RTC Ta Start time	803	R/WC	3	Time	-	RTC Ta Start time
RTC Tb Start time	806	R/WC	3	Time	-	RTC Tb Start time
RTC Tc Start time	809	R/WC	3	Time	-	RTC Tc Start time

Register alias	Register start address (Decimal system)	Operation Read/Write	Size	Type	Unit	Description
RTC Td Start time	812	R/WC	3	Time	-	RTC Td Start time
RTC Te Start time	815	R/WC	3	Time		RTC Te Start time
RTC Tf Start time	818	R/WC	3	Time	-	RTC Tf Start time
RTC Ta tariff selection	821	R/WC	1	UInt16	-	Ta tariff selection 0-5=Tariff 1-Tariff 6
RTC Tb tariff selection	822	R/WC	1	UInt16	-	Tb tariff selection 0-5=Tariff 1-Tariff 6
RTC Tc tariff selection	823	R/WC	1	UInt16	-	Tc tariff selection 0-5=Tariff 1-Tariff 6
RTC Td tariff selection	824	R/WC	1	UInt16	-	Td tariff selection 0-5=Tariff 1-Tariff 6
RTC Te tariff selection	825	R/WC	1	UInt16	-	Te tariff selection 0-5=Tariff 1-Tariff 6
RTC Tf tariff selection	826	R/WC	1	UInt16	-	Tf tariff selection 0-5=Tariff 1-Tariff 6

## 8..12 Voltage, current, power and power factor

Register alias	Register start address (Decimal system)	Operation Read/Write	Size	Type	Unit	Description
<b>Current</b>						
IA	1000	R	2	Float32	A	Phase L1 Current
IB	1002	R	2	Float32	A	Phase L2 Current
IC	1004	R	2	Float32	A	Phase L3 Current
Current Avg	1006	R	2	Float32	A	Average value of three-phase current, L1L2L3
IN	1008	R	2	Float32	A	N-phase Current
<b>Phase voltage</b>						
UA	1010	R	2	Float32	V	UA-UN voltage
UB	1012	R	2	Float32	V	UB-UN voltage
UC	1014	R	2	Float32	V	UC-UN voltage
Phase Voltage Avg	1016	R	2	Float32	V	Average value of three-phase phase voltage, L1L2L3
U0	1018	R	2	Float32	V	Zero sequence voltage
<b>Line voltage</b>						

Register alias	Register start address (Decimal system)	Operation Read/Write	Size	Type	Unit	Description
UAB	1020	R	2	Float32	V	UA-UB voltage
UBC	1022	R	2	Float32	V	UB-UC voltage
UCA	1024	R	2	Float32	V	UC-UA voltage
Line Voltage Avg	1026	R	2	Float32	V	Average value of three-phase line voltage
<b>Active power</b>						
PA	1028	R	2	Float32	kW	Phase L1 Active power
PB	1030	R	2	Float32	kW	Phase L2 Active power
PC	1032	R	2	Float32	kW	Phase L3 Active power
PTotal	1034	R	2	Float32	kW	Total active power
<b>Reactive power</b>						
QA	1036	R	2	Float32	kVAR	Phase L1 Reactive power
QB	1038	R	2	Float32	kVAR	Phase L2 Reactive power
QC	1040	R	2	Float32	kVAR	Phase L3 Reactive power
QTotal	1042	R	2	Float32	kVAR	Total reactive power
<b>Apparent power</b>						
SA	1044	R	2	Float32	kVA	Phase L1 Apparent power
SB	1046	R	2	Float32	kVA	Phase L2 Apparent power
SC	1048	R	2	Float32	kVA	Phase L3 Apparent power
STotal	1050	R	2	Float32	kVA	Total apparent power
<b>Power factor</b>						
PFA	1052	R	2	Float32	-	Phase L1 Power factor
PFB	1054	R	2	Float32	-	Phase L2 Power factor
PFC	1056	R	2	Float32	-	Phase L3 Power factor
PFTotal	1058	R	2	Float32	-	Total power factor
<b>Fundamental power factor</b>						
DPFA	1060	R	2	Float32	-	Phase L1 Fundamental power factor
DPFB	1062	R	2	Float32	-	Phase L2 Fundamental power factor
DPFC	1064	R	2	Float32	-	Phase L3 Fundamental power factor
DPFTotal	1066	R	2	Float32	-	Total fundamental power factor
<b>Frequency</b>						
FreqA	1068	R	2	Float32	Hz	Phase L1 Frequency
FreqB	1070	R	2	Float32	Hz	Phase L2 Frequency
FreqC	1072	R	2	Float32	Hz	Phase L3 Frequency
FreqTotal	1074	R	2	Float32	Hz	Three-phase integrated frequency

## 8.13 Electric energy

There are two types of electric energy data: Int64 and UInt32, with different unit sizes.

When the total electric energy reaches  $1.0 \times 10^9$  kWh,  $1.0 \times 10^9$  kVarh, or  $1.0 \times 10^9$  kVah, the electric energy of each phase will be automatically reset.

Register alias	Register start address (Decimal system)	Operation Read/Write	Size	Type	Unit	Description
<b>Active energy-Int64</b>						
EPAImp	2500	R	4	Int64	Wh	Phase L1 Positive active energy
EPBImp	2504	R	4	Int64	Wh	Phase L2 Positive active energy
EPCImp	2508	R	4	Int64	Wh	Phase L3 Positive active energy
EPImp	2512	R	4	Int64	Wh	Total positive active energy
EPAExp	2516	R	4	Int64	Wh	Phase L1 Reverse active energy
EPBExp	2520	R	4	Int64	Wh	Phase L2 Reverse active energy
EPCExp	2524	R	4	Int64	Wh	Phase L3 Reverse active energy
EPExp	2528	R	4	Int64	Wh	Total reverse active energy
<b>Reactive energy-Int64</b>						
EQAImp	2532	R	4	Int64	VARh	Phase L1 Positive reactive energy
EQBImp	2536	R	4	Int64	VARh	Phase L2 Positive reactive energy
EQCImp	2540	R	4	Int64	VARh	Phase L3 Positive reactive energy
EQImp	2544	R	4	Int64	VARh	Total positive reactive energy
EQAExp	2548	R	4	Int64	VARh	Phase L1 Reverse reactive energy
EQBExp	2552	R	4	Int64	VARh	Phase L2 Reverse reactive energy
EQCExp	2556	R	4	Int64	VARh	Phase L3 Reverse reactive energy
EQExp	2560	R	4	Int64	VARh	Total Reverse reactive energy
<b>Apparent energy-Int64</b>						
ESA	2564	R	4	Int64	VAh	Phase L1 Apparent energy
ESB	2568	R	4	Int64	VAh	Phase L2 Apparent energy
ESC	2572	R	4	Int64	VAh	Phase L3 Apparent energy
ES	2576	R	4	Int64	VAh	Total apparent energy
UInt32 Energy						
<b>Active energy- UInt32</b>						
EPAImp	2600	R	2	UInt32	kWh	Phase L1 Positive active energy
EPBImp	2602	R	2	UInt32	kWh	Phase L2 Positive active energy
EPCImp	2604	R	2	UInt32	kWh	Phase L3 Positive active energy
EPImp	2606	R	2	UInt32	kWh	Total positive active energy
EPAExp	2608	R	2	UInt32	kWh	Phase L1 Reverse active energy



Register alias	Register start address (Decimal system)	Operation Read/Write	Size	Type	Unit	Description
EPBExp	2610	R	2	UInt32	kWh	Phase L2 Reverse active energy
EPCExp	2612	R	2	UInt32	kWh	Phase L3 Reverse active energy
EPExp	2614	R	2	UInt32	kWh	Total reverse active energy
<b>Reactive energy- UInt32</b>						
EQAImp	2616	R	2	UInt32	kVARh	Phase L1 Positive reactive energy
EQBImp	2618	R	2	UInt32	kVARh	Phase L2 Positive reactive energy
EQCImp	2620	R	2	UInt32	kVARh	Phase L3 Positive reactive energy
EQImp	2622	R	2	UInt32	kVARh	Total positive reactive energy
EQAExp	2624	R	2	UInt32	kVARh	Phase L1 Reverse reactive energy
EQBExp	2626	R	2	UInt32	kVARh	Phase L2 Reverse reactive energy
EQCExp	2628	R	2	UInt32	kVARh	Phase L3 Reverse reactive energy
EQExp	2630	R	2	UInt32	kVARh	Total reverse reactive energy
<b>Apparent energy-UInt32</b>						
ESA	2632	R	2	UInt32	kVAh	Phase L1 Apparent energy
ESB	2634	R	2	UInt32	kVAh	Phase L2 Apparent energy
ESC	2636	R	2	UInt32	kVAh	Phase L3 Apparent energy
ES	2638	R	2	UInt32	kVAh	Total apparent energy

## 8..14 Tariff energy

There are two types of tariff energy data: Int64 and UInt32, with different unit sizes.

When the tariff energy reaches  $1.0 \times 10^9$  kWh, each tariff energy will be automatically reset.

Register alias	Register start address (Decimal system)	Operation Read/Write	Size	Type	Unit	Description
<b>Tariff energy-Int64</b>						
ET1	2700	R	4	Int64	Wh	Tariff 1 Active energy
ET2	2704	R	4	Int64	Wh	Tariff 2 Active energy
ET3	2708	R	4	Int64	Wh	Tariff 3 Active energy
ET4	2712	R	4	Int64	Wh	Tariff 4 Active energy
ET5	2716	R	4	Int64	Wh	Tariff 5 Active energy
ET6	2720	R	4	Int64	Wh	Tariff 6 Active energy
<b>Tariff energy-UInt32</b>						
ET1	2750	R	2	UInt32	kWh	Tariff 1 Active energy
ET2	2752	R	2	UInt32	kWh	Tariff 2 Active energy
ET3	2754	R	2	UInt32	kWh	Tariff 3 Active energy

Register alias	Register start address (Decimal system)	Operation Read/Write	Size	Type	Unit	Description
ET4	2756	R	2	UInt32	kWh	Tariff 4 Active energy
ET5	2758	R	2	UInt32	kWh	Tariff 5 Active energy
ET6	2760	R	2	UInt32	kWh	Tariff 6 Active energy

## 8.15 Demand parameters

Register alias	Register start address (Decimal system)	Operation Read/Write	Size	Type	Unit	Description
<b>Basic parameters of demand</b>						
DMDMethod	3000	R/WC	1	UInt16	-	Demand calculation method: 0=Sliding type 1=Fixed type
DMD block	3001	R/RC	1	UInt16	Minute	Demand interval
PDMD Reset Time	3002	R	4	Date time	-	Max demand reset date and time
<b>Power demand</b>						
PADemand	3020	R	2	Float32	kW	Phase L1 Current active power demand
PAPeakDemand	3022	R	2	Float32	kW	Phase L1 Max demand of active power
PAPeakDemandDate	3024	R	4	Date time	-	Phase L1 Time of occurrence for Max demand of active power
PBDemand	3028	R	2	Float32	kW	Phase L2 Current active power demand
PBPeakDemand	3030	R	2	Float32	kW	Phase L2 Max demand of active power
PBPeakDemandDate	3032	R	4	Date time	-	Phase L2 Occurrence time of max active power demand
PCDemand	3036	R	2	Float32	kW	Phase L3 Current active power demand
PCPeakDemand	3038	R	2	Float32	kW	Phase L3 Max demand of active power
PCPeakDemandDate	3040	R	4	Date time	-	Phase L3 Occurrence time of max active power demand
PSUMDemand	3044	R	2	Float32	kW	Current total active power demand
PSUMPeakDemand	3046	R	2	Float32	kW	Total max active power demand
PSUMPeakDemandDate	3048	R	4	Date time	-	Occurrence time of total max active power demand

Register alias	Register start address (Decimal system)	Operation Read/Write	Size	Type	Unit	Description
QADemand	3052	R	2	Float32	kVar	Phase L1 Current reactive power demand
QAPeakDemand	3054	R	2	Float32	kVar	Phase L1 Max demand of reactive power
QAPeakDemand Date	3056	R	4	Date time	-	Phase L1 Occurrence time of max reactive power demand
QBDemand	3060	R	2	Float32	kVar	Phase L2 Current reactive power demand
QBPeakDemand	3062	R	2	Float32	kVar	Phase L2 Max demand of reactive power
QBPeakDemand Date	3064	R	4	Date time	-	Phase L2 Occurrence time of max reactive power demand
QCDemand	3068	R	2	Float32	kVar	Phase L3 Current reactive power demand
QCPeakDemand	3070	R	2	Float32	kVar	Phase L3 Max demand of reactive power
QCPeakDemand Date	3072	R	4	Date time	-	Phase L3 Occurrence time of max reactive power demand
QSUMDemand	3076	R	2	Float32	kVar	Current total reactive power demand
QSUMPeakDemand	3078	R	2	Float32	kVar	Max demand of total reactive power
QSUMPeakDemandDate	3080	R	4	Date time	-	Occurrence time of total max reactive power demand
SADemand	3084	R	2	Float32	kVa	Phase L1 Current apparent power demand
SAPeakDemand	3086	R	2	Float32	kVa	Phase L1 Max apparent power demand
SAPeakDemandDate	3088	R	4	Date time	-	Phase L1 Occurrence time of max apparent power demand
SBDemand	3092	R	2	Float32	kVa	Phase L2 Current apparent power demand
SBPeakDemand	3094	R	2	Float32	kVa	Phase L2 Max apparent power demand
SBPeakDemandDate	3096	R	4	Date time	-	Phase L2 Occurrence time of max apparent power demand
SCDemand	3100	R	2	Float32	kVa	Phase L3 Current apparent power demand
SCPeakDemand	3102	R	2	Float32	kVa	Phase L3 Max apparent power demand
SCPeakDemandDate	3104	R	4	Date time	-	Phase L3 Occurrence time of max apparent power demand
SSUMDemand	3108	R	2	Float32	kVa	Current total apparent power demand
SSUMPeakDemand	3110	R	2	Float32	kVa	Total of max apparent power demand

Register alias	Register start address (Decimal system)	Operation Read/W rite	Size	Type	Unit	Description
SSUMPeakDemandDate	3112	R	4	Date time	-	Occurrence time of total max apparent power demand

## 8..16 Voltage and current harmonics

Register name	Register start address (Decimal system)	Operation	Size	Type	Unit	Description
<b>Current harmonic percentage</b>						
IATHD	4000	R	2	Float32	%	Phase L1 current: Percentage of total harmonic
IBTHD	4002	R	2	Float32	%	Phase L2 current: Percentage of total harmonic
ICTHD	4004	R	2	Float32	%	Phase L3 current: Percentage of total harmonic
IATOHd	4006	R	2	Float32	%	Phase L1 current: Odd total harmonic percentage
IBTOHD	4008	R	2	Float32	%	Phase L2 current: Odd total harmonic percentage
ICTOHD	4010	R	2	Float32	%	Phase L3 current: Odd total harmonic percentage
IATEHD	4012	R	2	Float32	%	Phase L1 current: Even total harmonic percentage
IBTEHD	4014	R	2	Float32	%	Phase L2 current: Even total harmonic percentage
ICTEHD	4016	R	2	Float32	%	Phase L3 current: Even total harmonic percentage
IAHD1	4018	R	2	Float32	%	Phase L1 current: 1st harmonic percentage
IBHD1	4020	R	2	Float32	%	Phase L2 current: 1st harmonic percentage
ICHHD1	4022	R	2	Float32	%	Phase L3 current: 1st harmonic percentage
...	4024-4311	...	...	...	...	Phase L1L2L3 current: 2nd-49th harmonic percentage
IAHD50	4312	R	2	Float32	%	Phase L1 current: 50th harmonic percentage
IBHD50	4314	R	2	Float32	%	Phase L2 current: 50th harmonic percentage
ICHHD50	4316	R	2	Float32	%	Phase L3 current: 50th harmonic percentage
<b>Current harmonic value</b>						

Register name	Register start address (Decimal system)	Operation	Size	Type	Unit	Description
IAHDV1	4400	R	2	Float32	A	Phase L1 current: Fundamental current value
IBHDV1	4402	R	2	Float32	A	Phase L2 current: Fundamental current value
ICHDV1	4404	R	2	Float32	A	Phase L3 current: Fundamental current value
...	4406-4693	...	...	...	...	Phase L1L2L3 current: 2nd-49th harmonic current value
IAHDV50	4694	R	2	Float32	A	Phase L1 current: 50th harmonic current value
IBHDV50	4696	R	2	Float32	A	Phase L2 current: 50th harmonic current value
ICHDV50	4698	R	2	Float32	A	Phase L3 current: 50th harmonic current value
<b>Percentage of voltage harmonics</b>						
UATHD	5000	R	2	Float32	%	Phase L1 voltage: Percentage of total harmonic
UBTHD	5002	R	2	Float32	%	Phase L2 voltage: Percentage of total harmonic
UCTHD	5004	R	2	Float32	%	Phase L3 voltage: Percentage of total harmonic
UATOHD	5006	R	2	Float32	%	Phase L1 voltage: Odd total harmonic percentage
UBTOHD	5008	R	2	Float32	%	Phase L2 voltage: Odd total harmonic percentage
UCTOHD	5010	R	2	Float32	%	Phase L3 voltage: Odd total harmonic percentage
UATEHD	5012	R	2	Float32	%	Phase L1 voltage: Even total harmonic percentage
UBTEHD	5014	R	2	Float32	%	Phase L2 voltage: Even total harmonic percentage
UCTEHD	5016	R	2	Float32	%	Phase L3 voltage: Even total harmonic percentage
UAHD1	5018	R	2	Float32	%	Phase L1 voltage: 1st harmonic percentage
UBHD1	5020	R	2	Float32	%	Phase L2 voltage: 1st harmonic percentage
UCHD1	5022	R	2	Float32	%	Phase L3 voltage: 1st harmonic percentage
...	5024-5311	...	...	...	...	Phase L1L2L3 voltage: 2nd-49th harmonic percentage
UAHD50	5312	R	2	Float32	%	Phase L1 voltage: 50th harmonic percentage
UBHD50	5314	R	2	Float32	%	Phase L2 voltage: 50th harmonic percentage

Register name	Register start address (Decimal system)	Operation	Size	Type	Unit	Description
UCHD50	5316	R	2	Float32	%	Phase L3 voltage: 50th harmonic percentage
<b>Voltage harmonic value</b>						
UAHDV1	5400	R	2	Float32	V	Phase L1 voltage: 1st harmonic voltage value
UBHDV1	5402	R	2	Float32	V	Phase L2 voltage: 1st harmonic voltage value
UCHDV1	5404	R	2	Float32	V	Phase L3 voltage: 1st harmonic voltage value
...	5406-5693	...	...	...	...	Phase L1L2L3 voltage: 2nd-49th harmonic voltage value
UAHDV50	5694	R	2	Float32	V	Phase L1 voltage: 50th harmonic voltage value
UBHDV50	5696	R	2	Float32	V	Phase L2 voltage: 50th harmonic voltage value
UCHDV50	5698	R	2	Float32	V	Phase L3 voltage: 50th harmonic voltage value

## 8.17 Max and min value

Register name	Register start address (Decimal system)	Operation	Size	Type	Unit	Description
<b>Current Max and min value</b>						
IA Max	6000	R	2	Float32	A	Phase L1 Maxi current
IB Max	6002	R	2	Float32	A	Phase L2 Maxi current
IC Max	6004	R	2	Float32	A	Phase L3 Maxi current
I AVG Max	6006	R	2	Float32	A	Max three-phase average current
IN Max	6008	R	2	Float32	A	Max value of N-phase current
IA Min	6010	R	2	Float32	A	Phase L1 Min current
IB Min	6012	R	2	Float32	A	Phase L2 Min current
IC Min	6014	R	2	Float32	A	Phase L3 Min current
I AVG Min	6016	R	2	Float32	A	Min three-phase average current
IN Min	6018	R	2	Float32	A	Min value of N-phase current
<b>Voltage Max and min value</b>						
UA Max	6020	R	2	Float32	V	Phase UA-UN: Max voltage
UB Max	6022	R	2	Float32	V	Phase UB-UN: Max voltage
UC Max	6024	R	2	Float32	V	Phase UC-UN: Max voltage
Phase	6026	R	2	Float32	V	Max of average phase voltage of

UAVGMax						three phase
UA Min	6030	R	2	Float32	V	Phase UA-UN: Min Voltage
UB Min	6032	R	2	Float32	V	Phase UB-UN: Min Voltage
UC Min	6034	R	2	Float32	V	Phase UC-UN: Min Voltage
UAVGMin	6036	R	2	Float32	V	Min of average phase voltage of three phase
UAB Max	6040	R	2	Float32	V	UA-UB Max line voltage
UBC Max	6042	R	2	Float32	V	UB-UC Max line voltage
UCA Max	6044	R	2	Float32	V	UC-UA Max line voltage
LineUAVGMax	6046	R	2	Float32	V	Maximum of average line voltage of three phase
UAB Min	6050	R	2	Float32	V	UA-UB Min Line voltage
UBC Min	6052	R	2	Float32	V	UB-UC Min Line voltage
UCA Min	6054	R	2	Float32	V	UC-UA Min Line voltage
LineUAVGMin	6056	R	2	Float32	V	Min of average line voltage of three phase
<b>Max/min active power</b>						
PA Max	6060	R	2	Float32	kW	Phase L1 Max active power
PB Max	6062	R	2	Float32	kW	Phase L2 Max active power
PC Max	6064	R	2	Float32	kW	Phase L3 Max active power
PSUMMax	6066	R	2	Float32	kW	Max three-phase total active power
PA Min	6070	R	2	Float32	kW	Phase L1 Min active power
PB Min	6072	R	2	Float32	kW	Phase L2 Min active power
PC Min	6074	R	2	Float32	kW	Phase L3 Min active power
PSUMMin	6076	R	2	Float32	kW	Min value of three-phase total active power
<b>Max/min reactive power</b>						
QA Max	6080	R	2	Float32	kVar	Phase L1 Max reactive power
QB Max	6082	R	2	Float32	kVar	Phase L2 Max reactive power
QC Max	6084	R	2	Float32	kVar	Phase L3 Max reactive power
QSUMMax	6086	R	2	Float32	kVar	Max three-phase total reactive power
QA Min	6090	R	2	Float32	kVar	Phase L1 Min reactive power
QB Min	6092	R	2	Float32	kVar	Phase L2 Min reactive power
QC Min	6094	R	2	Float32	kVar	Phase L3 Min reactive power
QSUMMin	6096	R	2	Float32	kVar	Min value of three-phase total reactive power
<b>Max/min apparent power</b>						
SA Max	6100	R	2	Float32	kVa	Phase L1 Max apparent power
SB Max	6102	R	2	Float32	kVa	Phase L2 Max apparent power
SC Max	6104	R	2	Float32	kVa	Phase L3 Max apparent power
SSUMMax	6106	R	2	Float32	kVa	Max three-phase total apparent power

SA Min	6110	R	2	Float32	kVa	Phase L1 Min apparent power
SB Min	6112	R	2	Float32	kVa	Phase L2 Min apparent power
SC Min	6114	R	2	Float32	kVa	Phase L3 Min apparent power
SSUMMin	6116	R	2	Float32	kVa	Min value of three-phase total apparent power

## 8..18 Unbalance

Register name	Register start address (Decimal system)	Operation	Size	Type	Unit	Description
Voltage negative sequence unbalance	7000	R	2	Float32	%	Voltage negative sequence unbalance
Voltage zero-sequence unbalance	7002	R	2	Float32	%	Voltage zero-sequence unbalance
Current negative sequence unbalance	7004	R	2	Float32	%	Current negative sequence unbalance
Current zero-sequence unbalance	7006	R	2	Float32	%	Current zero-sequence unbalance

## 8..19 Current K factor

Register name	Register start address (Decimal system)	Operation	Size	Type	Unit	Description
<b>Current K factor</b>						
KFIA	8000	R	2	Float32	-	Phase L1 Current K factor
KFIB	8002	R	2	Float32	-	Phase L2 Current K factor
KFIC	8004	R	2	Float32	-	Phase L3 Current K factor



## 8..20 Voltage and current angle

Register name	Register start address (Decimal system)	Operation	Size	Type	Unit	Description
<b>Voltage angle:</b>						
UA	8100	R	2	Float32	°	Phase L1 Voltage angle
UB	8102	R	2	Float32	°	Phase L2 Voltage angle
UC	8104	R	2	Float32	°	Phase L3 Voltage angle
<b>Current angle:</b>						
IA	8106	R	2	Float32	°	Phase L1 Current angle
IB	8108	R	2	Float32	°	Phase L2 Current angle
IC	8110	R	2	Float32	°	Phase L3 Current angle
<b>Angle between voltage and current:</b>						
UIA	8112	R	2	Float32	°	Phase L1 Angle between voltage and current
UIB	8114	R	2	Float32	°	Phase L2 Angle between voltage and current
UIC	8116	R	2	Float32	°	Phase L3 Angle between voltage and current

## 8..21 Alarm

Register name	Register start address (Decimal system)	Operation	Size	Type	Unit	Description
<b>Alarm Bitmap</b>						
<b>Enabled Alarm Bitmap</b>						
Enable Alarm Bitmap 1	10000	R	1	Bitmap	-	0=Alarm Disable 1=Alarm Enable Bit N(0-15)=Alarm ID N(1-16)
Enable Alarm Bitmap 2	10001	R	1	Bitmap	-	0=Alarm Disable 1=Alarm Enable Bit N(0-15)=Alarm ID N(17-32)
<b>Active alarm bitmap</b>						
Activate Alarm Bitmap 1	10010	R	1	Bitmap	-	0=Alarm not active 1=Alarm active Bit N(0-15)=Alarm ID N(1-16)
Activate Alarm Bitmap 2	10011	R	1	Bitmap	-	0=Alarm not active 1=Alarm active Bit N(0-15)=Alarm ID N(17-32)

Register name	Register start address (Decimal system)	Operation	Size	Type	Unit	Description
<b>Current alarm output bit</b>						
<i>(Note: there can be at most one alarm output at the same time)</i>						
Current alarm output bitmap 1	10020	R	1	Bitmap	-	0=Alarm not output 1=Alarm output Bit N(0-15)=Alarm ID N(1-16)
Current alarm output bitmap 2	10021	R	1	Bitmap	-	0=Alarm not output 1=Alarm output Bit N(0-15)=Alarm ID N(17-32)
<b>Alarm parameters</b>						
<b>Over current, each phase</b> <i>(Note: if one phase exceeds the activation threshold, an alarm will be generated; if all phases are below the alarm release point, the alarm will be released)</i>					<b>Alarm ID=1</b>	
Enabling state	10100	R/WC	1	UInt16	-	Enabling state 0=Disable 1=Enable
Activate threshold	10102	R/WC	2	Float32	A	Alarm activate threshold
Alarm release point	10104	R/WC	2	Float32	%	Error percentage of alarm release point relative to alarm activation threshold Example: <i>Alarm activation threshold =100A Alarm release point =5% When the current value is less than <math>100-100 * 5\%=95A</math>, the alarm is released</i>
Buzzer output correlation	10106	R/WC	1	UInt16	-	Buzzer output correlation 0=No correlation 1=Correlation
Relay output correlation	10107	R/WC	1	UInt16	-	Relay output correlation 0=No correlation 1=Correlation <i>(Note: control is only effective when the relay output mode is alarm output mode)</i>
<b>Under current, each phase</b>					<b>Alarm ID=2</b>	
Enabling state	10120	R/WC	1	UInt16	-	Enabling state 0=Disable 1=Enable
Activate threshold	10122	R/WC	2	Float32	A	Alarm activation threshold
Alarm release point	10124	R/WC	2	Float32	%	Error percentage of alarm release point relative to alarm activation threshold

Register name	Register start address (Decimal system)	Operation	Size	Type	Unit	Description
Buzzer output correlation	10126	R/WC	1	UInt16	-	Buzzer output correlation 0=No correlation 1=Correlation
Relay output correlation	10127	R/WC	1	UInt16	-	Relay output correlation 0=No correlation 1=Correlation
<b>Over phase voltage, L-N</b>						<b>Alarm ID=3</b>
Enabling state	10140	R/WC	1	UInt16	-	Enabling state 0=Disable 1=Enable
Activate threshold	10142	R/WC	2	Float32	V	Alarm activation threshold
Alarm release point	10144	R/WC	2	Float32	%	Error percentage of alarm release point relative to alarm activation threshold
Buzzer output correlation	10146	R/WC	1	UInt16	-	Buzzer output correlation 0=No correlation 1=Correlation
Relay output correlation	10147	R/WC	1	UInt16	-	Relay output correlation 0=No correlation 1=Correlation
<b>Under phase voltage, L-N</b>						<b>Alarm ID=4</b>
Enabling state	10160	R/WC	1	UInt16	-	Enabling state 0=Disable 1=Enable
Activate threshold	10162	R/WC	2	Float32	V	Alarm activation threshold
Alarm release point	10164	R/WC	2	Float32	%	Error percentage of alarm release point relative to alarm activation threshold
Buzzer output correlation	10166	R/WC	1	UInt16	-	Buzzer output correlation 0=No correlation 1=Correlation
Relay output correlation	10167	R/WC	1	UInt16	-	Relay output correlation 0=No correlation 1=Correlation
<b>Overline voltage, L-L</b>						<b>Alarm ID=5</b>
Enabling state	10180	R/WC	1	UInt16	-	Enabling state 0=Disable 1=Enable
Activate threshold	10182	R/WC	2	Float32	V	Alarm activation threshold
Alarm release point	10184	R/WC	2	Float32	%	Error percentage of alarm release point relative to alarm activation threshold

Register name	Register start address (Decimal system)	Operation	Size	Type	Unit	Description
Buzzer output correlation	10186	R/WC	1	UInt16	-	Buzzer output correlation 0=No correlation 1=Correlation
Relay output correlation	10187	R/WC	1	UInt16	-	Relay output correlation 0=No correlation 1=Correlation
<b>Underline voltage, L-L</b>						<b>Alarm ID=6</b>
Enabling state	10200	R/WC	1	UInt16	-	Enabling state 0=Disable 1=Enable
Activate threshold	10202	R/WC	2	Float32	V	Alarm activation threshold
Alarm release point	10204	R/WC	2	Float32	%	Error percentage of alarm release point relative to alarm activation threshold
Buzzer output correlation	10206	R/WC	1	UInt16	-	Buzzer output correlation 0=No correlation 1=Correlation
Relay output correlation	10207	R/WC	1	UInt16	-	Relay output correlation 0=No correlation 1=Correlation
<b>Overpower, total active (absolute value)</b>						<b>Alarm ID=10</b>
Enabling state	10220	R/WC	1	UInt16	-	Enabling state 0=Disable 1=Enable
Activate threshold	10222	R/WC	2	Float32	kW	Alarm activation threshold
Alarm release point	10224	R/WC	2	Float32	%	Error percentage of alarm release point relative to alarm activation threshold
Buzzer output correlation	10226	R/WC	1	UInt16	-	Buzzer output correlation 0=No correlation 1=Correlation
Relay output correlation	10227	R/WC	1	UInt16	-	Relay output correlation 0=No correlation 1=Correlation
<b>Overpower, total reactive (absolute value)</b>						<b>Alarm ID=14</b>
Enabling state	10240	R/WC	1	UInt16	-	Enabling state 0=Disable 1=Enable
Activate threshold	10242	R/WC	2	Float32	kVar	Alarm activation threshold
Alarm release point	10244	R/WC	2	Float32	%	Error percentage of alarm release point relative to alarm activation threshold

Register name	Register start address (Decimal system)	Operation	Size	Type	Unit	Description
Buzzer output correlation	10246	R/WC	1	UInt16	-	Buzzer output correlation 0=No correlation 1=Correlation
Relay output correlation	10247	R/WC	1	UInt16	-	Relay output correlation 0=No correlation 1=Correlation
<b>Overpower, total apparent</b>						<b>Alarm ID=18</b>
Enabling state	10260	R/WC	1	UInt16	-	Enabling state 0=Disable 1=Enable
Activate threshold	10262	R/WC	2	Float32	kVA	Alarm activation threshold
Alarm release point	10264	R/WC	2	Float32	%	Error percentage of alarm release point relative to alarm activation threshold
Buzzer output correlation	10266	R/WC	1	UInt16	-	Buzzer output correlation 0=No correlation 1=Correlation
Relay output correlation	10267	R/WC	1	UInt16	-	Relay output correlation 0=No correlation 1=Correlation
<b>Overdemand, total active (absolute value), current</b>						<b>Alarm ID=20</b>
Enabling state	10280	R/WC	1	UInt16	-	Enabling state 0=Disable 1=Enable
Activate threshold	10282	R/WC	2	Float32	kW	Alarm activation threshold
Alarm release point	10284	R/WC	2	Float32	%	Error percentage of alarm release point relative to alarm activation threshold
Buzzer output correlation	10286	R/WC	1	UInt16	-	Buzzer output correlation 0=No correlation 1=Correlation
Relay output correlation	10287	R/WC	1	UInt16	-	Relay output correlation 0=No correlation 1=Correlation
<b>Overdemand, total reactive power (absolute value), current</b>						<b>Alarm ID=21</b>
Enabling state	10300	R/WC	1	UInt16	-	Enabling state 0=Disable 1=Enable
Activate threshold	10302	R/WC	2	Float32	kVar	Alarm activation threshold
Alarm release point	10304	R/WC	2	Float32	%	Error percentage of alarm release point relative to alarm activation threshold

Register name	Register start address (Decimal system)	Operation	Size	Type	Unit	Description
Buzzer output correlation	10306	R/WC	1	UInt16	-	Buzzer output correlation 0=No correlation 1=Correlation
Relay output correlation	10307	R/WC	1	UInt16	-	Relay output correlation 0=No correlation 1=Correlation
<b>Excess demand, total apparent, current</b>						<b>Alarm ID=22</b>
Enabling state	10320	R/WC	1	UInt16	-	Enabling state 0=Disable 1=Enable
Activate threshold	10322	R/WC	2	Float32	kVA	Alarm activation threshold
Alarm release point	10324	R/WC	2	Float32	%	Error percentage of alarm release point relative to alarm activation threshold
Buzzer output correlation	10326	R/WC	1	UInt16	-	Buzzer output correlation 0=No correlation 1=Correlation
Relay output correlation	10327	R/WC	1	UInt16	-	Relay output correlation 0=No correlation 1=Correlation
<b>Over THD-U (total voltage harmonic), each phase</b>						<b>Alarm ID=30</b>
Enabling state	10340	R/WC	1	UInt16	-	Enabling state 0=Disable 1=Enable
Activate threshold	10342	R/WC	2	Float32	%	Alarm activation threshold
Alarm release point	10344	R/WC	2	Float32	%	Error percentage of alarm release point relative to alarm activation threshold
Buzzer output correlation	10346	R/WC	1	UInt16	-	Buzzer output correlation 0=No correlation 1=Correlation
Relay output correlation	10347	R/WC	1	UInt16	-	Relay output correlation 0=No correlation 1=Correlation
<b>Over THD-I (total harmonic of current), each phase</b>						<b>Alarm ID=31</b>
Enabling state	10360	R/WC	1	UInt16	-	Enabling state 0=Disable 1=Enable
Activate threshold	10362	R/WC	2	Float32	%	Alarm activation threshold
Alarm release point	10364	R/WC	2	Float32	%	Error percentage of alarm release point relative to alarm activation threshold

Register name	Register start address (Decimal system)	Operation	Size	Type	Unit	Description
Buzzer output correlation	10366	R/WC	1	UInt16	-	Buzzer output correlation 0=No correlation 1=Correlation
Relay output correlation	10367	R/WC	1	UInt16	-	Relay output correlation 0=No correlation 1=Correlation

## 9 Revision History

Version	Date	Content modification	Reviser
V1.0	2022/12/22	Create documents	Walter
V1.1	2023/01/09	<ol style="list-style-type: none"><li>1. Added current direction setting Modbus register</li><li>2. Add the current channel selection Modbus register</li><li>3. Unified document format</li></ol>	Walter



