

MK-354 Three-phase inductive electric energy metering detector

1. Product description

- 1.1 Introduction
- 1.2 Features
- 1.3 Technical parameters

2. Application

- 2.1 Appearance and installation
- 2.2 Terminal Definition
- 2.3 Typical wiring
- 2.4 Application Description

3. Modbus Registers

4. Modbus Communication Protocol

5. Precautions



1. Product Introduction

1.1、 Introduction

MK-354 Three phase inductive electric energy metering detector is a metering product developed by our company using microelectronics technology and dedicated large-scale integrated circuits, digital sampling and processing technology, SMT technology and other advanced technologies, with completely independent intellectual property rights. The technical performance of the detector meets the relevant technical requirements of the 1.0 level three-phase active energy meter in the IEC 62053-2 standard, and can directly and accurately measure the voltage, current, power, power factor, reactive power and other electrical parameters in the three-phase AC power grid with a rated frequency of 50Hz or 60Hz. The detector has a built-in RS485 communication interface and adopts MODBUS-RTU communication protocol, which is convenient for connection with various AMR systems. It has the characteristics of good reliability, small size, light weight, beautiful appearance and easy installation.

MK-354 Three phase inductive electric energy meter can be widely used in energy-saving transformation , new energy charging piles, electricity, communications, railways, transportation, environmental protection, petrochemicals, steel and other industries to monitor the current and power consumption of AC equipment.

1.2、 Features

- 1.2.1. Collect three-phase AC parameters, including voltage, current, power, electric energy and other electrical parameters, with complete information.
- 1.2.2. Adopting special measurement chip and effective value measurement method, the measurement accuracy is high.
- 1.2.3. With 1 RS-485 communication interface.
- 1.2.4. The communication protocol adopts standard Modbus-RTU, which has good compatibility and is convenient for programming.
- 1.2.5. RS-485 communication interface with ESD protection circuit.
- 1.2.6. DC 9-24 V power supply.
- 1.2.7. It uses industrial-grade chips, has a built-in watchdog, and has complete lightning protection and anti-interference measures to ensure reliability.
- 1.2.8. High isolation voltage, withstand voltage up to AC: 3000V.
- 1.2.9. You can choose to use single-turn through-core transformers or split-type transformers of different specifications, which is convenient and easy to use.

(Note: Split-type current transformers are mainly used in industrial city grids, power transmission systems, and rural project transformation.

Easy to install, no need to disassemble the primary bus bar, can be operated with power on, and will not affect the normal power consumption of customers,

The project saves a lot of manpower, material resources and financial resources, and improves the efficiency of transformation.)

1.3 、 Technical Parameters

1.3.1 Three-phase AC input

- 1) Voltage range: three-phase four-wire input, 3*220/380V.
- 2) Current range: 50A, 80A, 100A, 250A, 500A, etc. are available, and external open current transformer models are available.

- 3) Signal processing: using a dedicated measurement chip, 24 -bit AD sampling.
- 4) Overload capacity: 1.2 times the range is sustainable. Instantaneous (<200mS) current 5 times, voltage 2 times the range is not damaged.
- 5) Input impedance: voltage channel > 1 k Ω / V.

1.3.2 Communication Interface

- 1) Interface type: 1 RS-485 interface.
- 2) Communication protocol: MODBUS-RTU protocol.
- 3) Data format: software-settable, " 8, N, 1" , " 8, E, 1" , " 8, O, 1" , " 8, N, 2" .
- 4) Communication rate: The communication interface baud rate can be set to 4800, 9600, 19200, 38400Bps, and the default communication format is "n, 8, 1", 9600bps.
- 5) Communication data :

Voltage, current, power, electric energy and other electrical parameters, see the Modbus data register list.

1.3.3 measurement accuracy

Voltage, current, power: $\pm 1.0\%$. Active energy level 1.

1.3.4 power supply

- 1) When powered by DC 9~24V, the peak voltage shall not exceed 30V. Typical power consumption: < 30mA.

1.3.5 isolation

Strong current and weak current are isolated by mutual inductor, and the isolation withstand voltage is > 3000V.

1.3.6 working environment

- 1) Working temperature: -20 ~ + 60 $^{\circ}\text{C}$. Storage temperature: -40~+85 $^{\circ}\text{C}$.
- 2) Relative humidity: 5~95%, no condensation (at 40 $^{\circ}\text{C}$) .
- 3) Altitude: 0~3000 meters.
- 4) Environment: No explosive, corrosive gases and conductive dust, no significant shaking, vibration and impact.

1.3.7 Temperature drift: $\leq 100\text{ppm}/^{\circ}\text{C}$.

1.3.8 Installation method: screw hole fixation.

1.3.9 Detector size: 114.7*89.9mm.

2. Application

2.1、 Product appearance



Figure 2.1 Product appearance

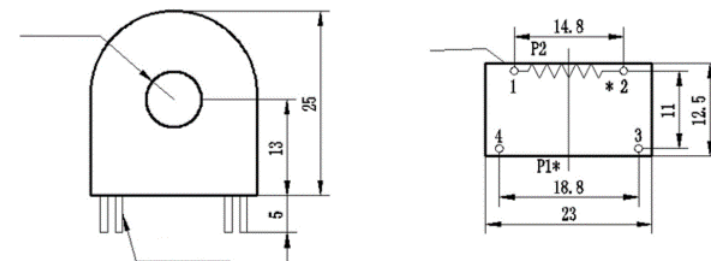

Dimensional drawing of 50A core-type current transformer

Terminal definition

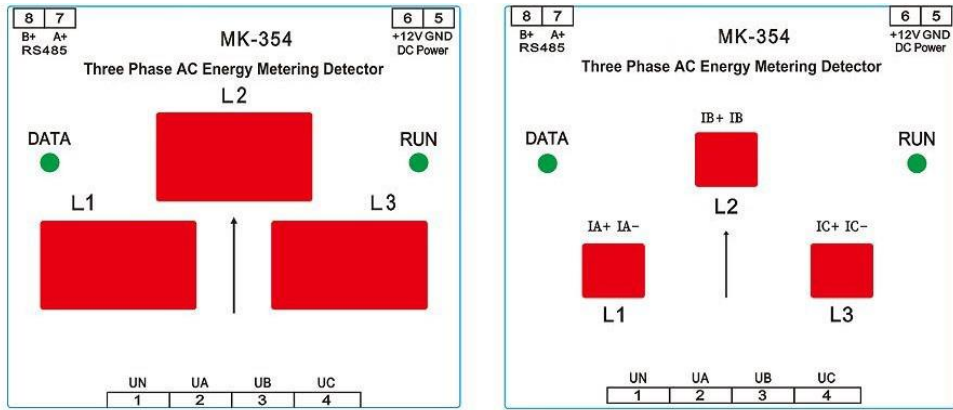

Figure 2.2.1 Product dimensions and functional pins

2.2、 Typical wiring

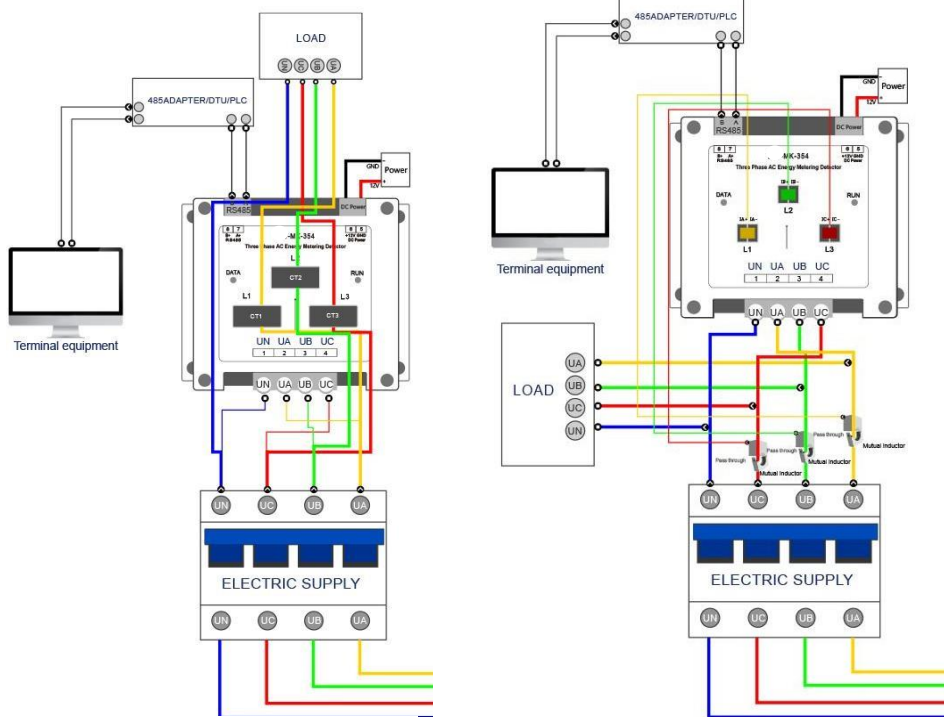

Figure 2.2.2 Product Function Pin Description

2.3、 Application Notes

Please wire correctly according to the product specifications and models and refer to the above diagrams. Make sure to disconnect all signal sources before wiring to avoid danger and damage to the equipment. After checking and confirming that the wiring is correct, turn on the power supply for testing.

After the power is turned on, the "Power" indicator light is always on, and the "Communication" indicator light flashes synchronously during communication data transmission.

When the product leaves the factory, it is set to the default configuration: address 1, baud rate 9600bps, data format "n, 8, 1", data update rate 1000ms, ratio 1.

354 product testing software we provide can be used to change and set product parameters and perform general product tests.

2.3.1、 RS-485 network connection:

The host usually only has an RS - 232 interface. In this case, it can be connected to the 485 network through an RS - 232/ RS -485 converter. It is recommended to use an isolated 485 converter to improve the reliability of the system.

The A+ and B- terminals of all devices on a bus are connected in parallel, and they cannot be connected in reverse. Up to 255 network modules can be connected to a line at the same time. Each network module can set its communication address. The communication connection should use shielded twisted pair cables with a wire diameter of not less than

①On board type

②External transformer type

0.5mm². when wiring, keep the communication line away from strong electric cables or other strong electric field environments.

The RS - 485 communication line should use shielded twisted pair cable. The communication distance of 485 can reach 1200 meters. When there are many RS485 devices connected to a bus, or a higher baud rate is used, the communication distance will be shortened accordingly. At this time, a 485 repeater can be used for expansion.

RS - 485 networking has a variety of topological structures, generally using linear connection that is, starting from the upper host, multiple devices are connected to the network one by one from near too far. At the farthest end, a 120 ~ 300 Ω / 0.25 watt terminal matching resistor can be connected (depending on the specific communication quality, that is, it does not need to be installed when the communication is very good).

2.4.2. Electric energy metering function:

Can provide three-phase voltage, current, power, power factor, active and reactive electric energy and other parameters.

The electricity data is a 4-byte unsigned number, which will not overflow if accumulated for 10 consecutive years and will be saved when the power is off.

3. MK-354 Modbus register list

Table 1: Measurement electrical parameter register and communication data table (function code 03H, read-only)

serial number	definition	Register address	read/write	Data types and calculation instructions
1	A phase voltage	0100H	read	Unsigned number, value=DATA/100, unit V
2	B phase voltage	0101H	read	Unsigned number, value=DATA/100, unit V
3	C phase voltage	0102H	read	Unsigned number, value=DATA/100, unit V
4	A phase current	0103H	read	Unsigned number, value=DATA/100, unit A
5	B phase current	0104H	read	Unsigned number, value = DATA/100, unit A
6	Phase C current	0105H	read	Unsigned number, value = DATA/100, unit A

7	Phase A active power	0106H	read	Unsigned number, value = DATA, unit is W
8	Phase B active power	0107H	read	Unsigned number, value = DATA, unit is W
9	Phase C active power	0108H	read	Unsigned number, value = DATA, unit is W
10	Three-phase total active power	0109H 010AH	read	Unsigned number, value=DATA, unit is W (The 0109H register corresponds to the high 16 bits)
11	Phase A reactive power	010BH	read	Unsigned number, value=DATA, unit is var
12	Phase B reactive power	010CH	read	Unsigned number, value=DATA, unit is var
13	C phase reactive power	010DH	read	Unsigned number, value=DATA, unit is var
14	Three-phase total reactive power	010EH 010FH	read	Unsigned number, value=DATA, unit is var
15	Phase A apparent power	0110H	read	Unsigned number, value = DATA, unit is VA
16	B phase apparent power	0111H	read	Unsigned number, value = DATA, unit is VA
17	Phase C apparent power	0112H	read	Unsigned number, value = DATA, unit is VA
18	Three-phase total apparent power	0113H 0114H	read	Unsigned number, value = DATA, unit is VA (0114H register corresponds to the upper 16 bits)
19	Voltage frequency	0115H	read	Unsigned number, value = DATA/100, unit is Hz
20	Phase A power factor	0116H	read	Unsigned number, value = DATA/1000

twenty one	Phase B power factor	0117H	read	Unsigned number, value = DATA/1000
twenty two	Phase C power factor	0118H	read	Unsigned number, value = DATA/1000
twenty three	Three-phase total power factor	0119H	read	Unsigned number, value = DATA/1000
twenty four	Phase A active energy	011AH 011BH	read	Unsigned number, value=DATA/100, unit is kWh
25	Phase B active energy	011CH 011DH	read	Unsigned number, value=DATA/100, unit is kWh
26	Phase C active energy	011EH 011FH	read	Unsigned number, value=DATA/100, unit is kWh
28	Three-phase active total electric energy	0120H 0121H	read	Unsigned number, value=DATA/100, unit is kWh
29	Phase A reactive energy	0122H 0123H	read	Unsigned number, value=DATA/100, unit is kvarh
30	B phase reactive energy	0124H 0125H	read	Unsigned number, value = DATA/100, unit is kvarh
31	C phase reactive energy	0126H 0127H	read	Unsigned number, value = DATA/100, unit is kvarh
32	Three-phase total reactive energy	0128H 0129H	read	Unsigned number, value = DATA/100, unit is kvarh
33	A phase	012AH	read	Unsigned number, value = DATA/100, unit is

	apparent energy	012BH		kVAh
34	B phase apparent energy	012CH 012DH	read	Unsigned number, value = DATA/100, unit is kVAh
35	C phase apparent energy	012EH 012FH	read	Unsigned number, value = DATA/100, unit is kVAh
36	Three-phase apparent total energy	0130H 0131H	read	Unsigned number, value = DATA/100, unit is kVAh
37	Current power direction	0132H	read	The high byte is not used, and the low byte bit7~bit0 are the corresponding bits of the total reactive power, C phase reactive power, B phase reactive power, A phase reactive power, total active power, C phase active power, B phase active power, and A phase active power status (0 is forward, 1 is reverse), see status word 1
38	Current alarm status	0133H	read	When the high byte bit0 is 1, it indicates reverse phase sequence, and 0 indicates normal phase sequence. Low byte bit6~bit4 indicates that the current of phase C~A exceeds the limit, bit2~bit0 indicates that the voltage of phase C~A exceeds the limit, see status word 2
39	A phase positive active energy	0134H 0135H	read	Unsigned number, value = DATA/100, unit is kWh
40	B phase forward active energy	0136H 0137H	read	Unsigned number, value=DATA/100, unit is kWh

41	Phase C forward active energy	0138H 0139H	read	Unsigned number, value=DATA/100, unit is kWh
42	Three-phase forward total active energy	013AH 013BH	read	Unsigned number, value=DATA/100, unit is kWh
43	Phase A reverses active electric energy	013CH 013DH	read	Unsigned number, value=DATA/100, unit is kWh
44	Phase B reverse active energy	013EH 013FH	read	Unsigned number, value=DATA/100, unit is kWh
45	C phase reverse active energy	0140H 0141H	read	Unsigned number, value = DATA/100, unit is kWh
46	Three-phase reverse total active energy	0142H 0143H	read	Unsigned number, value = DATA/100, unit is kWh
47	A phase positive reactive energy	0144H 0145H	read	Unsigned number, value = DATA/100, unit is kWh
48	B phase positive reactive energy	0146H 0147H	read	Unsigned number, value = DATA/100, unit is kWh
49	C phase positive reactive energy	0148H 0149H	read	Unsigned number, value = DATA/100, unit is kWh
50	Three-phase forward total reactive energy	014AH 014BH	read	Unsigned number, value = DATA/100, unit is kWh

51	A phase reverse reactive energy	014CH 014DH	read	Unsigned number, value = DATA/100, unit is kWh
52	B phase reverse reactive energy	014EH 014FH	read	Unsigned number, value = DATA/100, unit is kWh
53	C phase reverse reactive energy	0150H 0151H	read	Unsigned number, value = DATA/100, unit is kWh
54	Three-phase total reactive energy	0152H 0153H	read	Unsigned number, value = DATA/100, unit is kWh

Table 2: System parameter register address and communication data table (function code 03H read, 10H write)

Serial number	definition	Register Address	Read/Write	Specific instructions
1	Model 1	0000H	read	The value is 333H
2	Model 2	0001H	read	reserve
3	Voltage range	0002H	read	Default is 250V, value is FAH
4	Current range	0003H	read	The default is 50A, the value is 1F4H (10 times relationship)

5	Address and baud rate	0004H	read/write	<p>The default value is 0106H. the default address is 01H, and the default communication format is 8, N, 1,9600bps</p> <p>illustrate:</p> <p>The 8-bit high byte is the address, 1~255. 0 is the broadcast address.</p> <p>The high 2 bits of the low byte are the data format bits.</p> <p>"00" means 10 bits, no check, that is, "8, N, 1".</p> <p>"01" means 11 bits, even parity, that is, "8, E, 1".</p> <p>"10" means 11 bits, odd parity, that is, "8, O, 1".</p> <p>"11" means 11 bits, no parity, 2 stop bits, that is, "8, N, 2".</p> <p>The lower four bits of the low byte are the Baud rate, 5-4800bps, 6-9600bps, 7-19200bps.</p>
---	-----------------------	-------	------------	---

Table 3: Alarm upper limit register and communication data table (function code 03H reads, 10H writes)

serial number	definition	Register Address	Read/Write	Specific instructions
1	Voltage upper limit	0020H	Read/Write	Default value 0x104 = 260V
2	Current limit	0021H	Read/Write	Default value 0x1F4, 0x1F4/10=50A

Table 4: Power Direction Register (Status Word 1)

Bit7	Bit6	Bit5	Bit4	Bit3	Bit2	Bit1	Bit0
Total reactive power:	C phase reactive power:	B phase reactive power:	Phase A reactive power:	Total merit:	Active power of phase C:	Phase B active power:	Phase A active power:
1—Reverse	1—Reverse	1—Reverse	1—Reverse	1—Reverse	1—Reverse	1—Reverse	1—Reverse

Phase C	Phase B	Phase A	Unused	Phase C	Phase B	Phase A
1—Overcurrent	1—Overcurrent	1—Overcurrent		1—Overvoltage	1—Overvoltage	1—Overvoltage
0—Normal	0—Normal	0—Normal		0—Normal	0—Normal	0—Normal

Table 5: Meaning of alarm status indicator word (status word 2) :

Bit7	Bit6	Bit5	Bit4	Bit3	Bit2	Bit1	Bit0
Unused	Phase C current:	Phase B current:	Phase A current:	Unused	Phase C voltage:	Phase B voltage:	Phase A voltage:
	1—Overcurrent	1—Overcurrent	1—Overcurrent		1—Overvoltage	1—Overvoltage	1—Overvoltage
	0—Normal	0—Normal	0—Normal		0—Normal	0—Normal	0—Normal

4. MODBUS Communication Protocol

This module provides a serial asynchronous half-duplex RS485 communication interface, using the standard MODBUS-RTU protocol, and all kinds of data information can be transmitted on the communication line. Up to 255 modules can be connected on one line at the same time, and each module can set its communication address. The communication connection should use a shielded twisted pair with a copper mesh, with a wire diameter of not less than 0.5mm². When wiring, keep the communication line away from strong electric cables or other strong electric field environments.

The MODBUS protocol uses a master-slave response communication connection method on a communication line. First, the signal of the host computer is addressed to a terminal device (slave) with a unique address, and then the response signal sent by the terminal device is transmitted to the host in the opposite direction, that is: on a separate communication line, the signal transmits all communication data streams in two opposite directions (half-duplex working mode). The MODBUS protocol only allows communication between the host (PC, PLC, etc.) and the terminal device, and does not allow data exchange between independent terminal devices, so that each terminal device will not occupy the

Communication line when they are initialized, but is limited to responding to the query signal that reaches the machine.

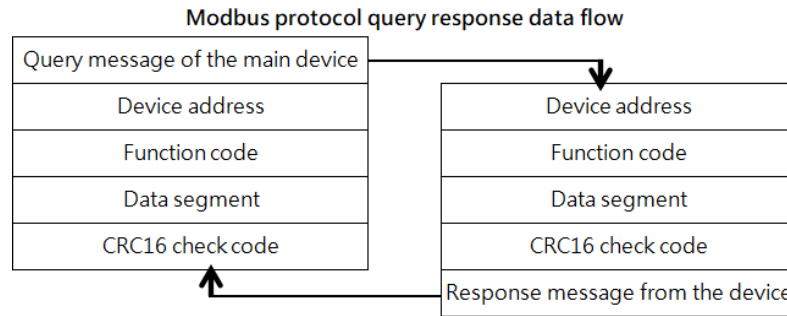

Host query: The query message frame includes the device address, function code, data information code, and check code. The address code indicates the slave device to be selected. The function code tells the selected slave device what function to perform, for example, function code 03 or 04 requires the slave device to read the register and return their contents. The data segment contains any additional information for the slave device to perform the function, and the check code is used to verify the correctness of a frame of information. The slave device provides a method to verify whether the message content is correct, which uses the CRC16 calibration rule.

Slave response: If the slave device generates a normal response, the response message contains the slave address code, function code, data information code and CRC16 check code. The data information code includes the data collected by the slave device: such as register value or status. If an error occurs, we agree that the slave will not respond.

We specify the communication data format used in this module: bits of each byte (1 start bit, 8 data bits, odd or even or no parity, 1 or 2 stop bits).

The structure of the data frame, that is, the message format:

Device Address	Function Code	Data segment	CRC16 checksum
1 byte	1 byte	N bytes	2 bytes (low byte first)

Device address: Consists of one byte. The address of each terminal device must be unique.

Only the addressed terminal will respond to the corresponding query.

Function code: tells the addressed terminal what function to perform. The following table lists the function codes supported by this series of modules and their functions.

Function Code	Function
03H	Read the value of one or more registers
10H	Write the value of one or more registers

Data segment: Contains the data required by the terminal to perform specific functions or the data collected when the terminal responds to queries. The content of this data may be numerical values, reference addresses or setting values.

Checksum: CRC16 occupies two bytes and contains a 16-bit binary value. The CRC value is calculated by the transmitting device and then attached to the data frame. The receiving device recalculates the CRC value when receiving data and then compares it with the value in the received CRC field. If the two values are not equal, an error has occurred.

The process of generating a CRC16 is:

- (1) Preset a 16-bit register to 0FFFFH (all 1s), called the CRC register.
- (2) Perform an XOR operation on the 8 bits of the first byte in the data frame and the low byte in the CRC register, and store the result back in the CRC register.
- (3) Shift the CRC register one bit to the right, fill the highest bit with 0, and shift the lowest bit out and check.
- (4) If the lowest bit is 0: repeat the third step (next shift). if the lowest bit is 1: perform an XOR operation on the CRC register and a preset fixed value (0A001H).
- (5) Repeat steps 3 and 4 until 8 shifts have been made. This completes the processing of a full eight bits.
- (6) Repeat steps 2 to 5 to process the next eight bits until all bytes have been processed.
- (7) The final value of the CRC register is the value of CRC16.

MODBUS-RTU communication protocol example:

4.1. Function code 0x03: Read multiple registers

Example: The host wants to read the data of three slave registers with address 01 and starting address 0100H.

Host sends: 01 03 01 00 00 03 04 37

Address function code starting address data length CRC code

Slave response: 01 03 06 56 11 56 22 56 33 1F 77

Address Function Code Return Bytes Register Data 1 Register 2 Register 3 CRC Code

4.2. Function code 0x10: Write multiple registers

Example: The host wants to save 0104H, 01F4H to the slave register with address 0020H, 0021H (the slave address code is 0x01)

Host sends: 01 10 00 20 00 02 04 01 04 01 F4 B1 9D

Address Function Code Starting Address Write Register Quantity Byte Count Save Data 1 2
CRC Code

Slave response: 01 10 00 20 00 02 40 02

Address function code starting address write register quantity CRC code

4.3 Description

The registers in the MODBUS-RTU communication protocol refer to 16 bits (i.e. 2 bytes), with the high bit first.

When setting parameters, be careful not to write illegal data (i.e. data values that exceed the data range limit).

The error code format returned by the slave is as follows:

Address code: 1 byte

Function code: 1 byte (the highest bit is 1)

Error code: 1 byte

CRC: 2 bytes

The response returns the following error code:

81: Illegal function code, that is, the received function code is not supported by the module.

82: Read or write an illegal data address, that is, the data location exceeds the module's readable or writable address range.

83: Illegal data value, that is, the data value received by the module from the host exceeds

The data range of the corresponding address.

4.4 Communication message example

4.4.1 Read data register (function code 03H): Read the voltage data of phase A, phase B, and phase C, a total of 6 registers, the results are: phase A voltage 231.51V, phase B voltage 229.32V, phase C voltage 230.56V, the module address is 1.

The host reads the data frame:

address	Order	Starting address (high first)	Register number (high digit first)	Check code (low digit first)
01H	03H	0 0 H, A0 H	00H,0 6 H	C5H , EAH

The module responds with a data frame:

address	Order	Data length	Data segment (6 bytes)	Check code
01H	03H	0 C H	43H,67H,82H,8FH,43H,65H,51H,ECH,43H,66H,8FH,5CH	88H,CDH

4.4.2 Write data register (function code 10H): Set the module address to 2, the baud rate to 19200bps, and the module address to 1.

The host writes data frame:

address	Order	initial address	Number of registers	Number of bytes	Data segment	Check code
01H	10H	00H , 04H	00H, 0 1H	0 2 H	0 2 H,0 7 H	E7H,76H

The module responds with a data frame:

addresses	Order	initial address	Number of registers	Check code
01H	10H	00H , 04H	00H, 0 1H	40H, 0 8H

5. Notes

- 1) Pay attention to the auxiliary power information on the product label. The auxiliary power level and polarity of the product must not be connected incorrectly, otherwise the product may be damaged.
- 2) Please connect correctly according to the product specifications and models and refer to the diagram. Before connecting, make sure to disconnect all signal sources and power to avoid danger and damage to the equipment. After checking and confirming that the wiring is correct, turn on the power for testing.
- 3) The voltage circuit or the secondary circuit of the PT cannot be short-circuited.
- 4) When there is current on the primary side of the CT, it is strictly forbidden to open the secondary circuit of the CT. It is strictly forbidden to connect wires or unplug terminals when there is current on the primary side of the CT.
- 5) When the product is used in an environment with strong electromagnetic interference, please pay attention to the shielding of the input and output signal lines.
- 6) When installing centrally, the minimum installation interval should not be less than 10mm.
- 7) This series of products does not have a lightning protection circuit inside. When the input and output feeder lines of the module are exposed to harsh outdoor weather environments, lightning protection measures should be taken.
- 8) Please do not damage or modify the product labels or logos, and do not disassemble or modify the product. Otherwise, our company will no longer provide the "three guarantees" (exchange, refund, and repair) service for this product.